

SPRING 2024



MODERN AG
S I N C E 1 9 4 7

8' PREDATOR

Operator's Manual

Click here to register your product!



P.O. BOX 790 • BEAUMONT, TX 77704
888.404.8908 • FAX: 888.404.8908
www.modernusa.com

INTRODUCTION

Your rotary cutter is designed primarily for weed, grass and brush to 3" diameter. With proper maintenance as described in the manual, your cutter will provide you with years of dependable service with a minimum of repairs.

It is recommended that all operators of this implement read this manual or be instructed of its contents as to safety, proper operation, and maintenance before beginning operation.

Your cutter has been assembled for operation with a tractor PTO input speed of 540. Verify your RPM with your local dealer prior to operation. Should you desire to change PTO input speed, contact your local dealer. This series of cutter is recommended for use with tractor PTO's rated at 45 - 50 HP minimum.

When ordering parts for the gear boxes and the drivelines, be sure to specify the serial number. The serial number is located on the angle located on top of cutter.

Chain guards, deflectors, driveline integral shields are standard equipment and need to be used at all times.

INTRODUCTION

This Rotary Cutter is designed with care and built with quality materials by skilled workers. Proper assembly, maintenance, and operating practices, as described in this manual, will help the owner/operator get years of satisfactory service from the machine.

The purpose of this manual is to familiarize, instruct, and train. The Assembly Section instructs the owner/operator in the correct assembly of the Cutter using standard and optional equipment. The Parts Listing section is designed to familiarize the owner/operator with replaceable parts on the Cutter. This section provides exploded assembly drawings of each cutter component illustrating each piece and the corresponding part number.

Careful use and timely service save extensive repairs and costly downtime losses. The Operation and Maintenance Sections of the manual train the owner/operator how to work the Cutter correctly and attend to appropriate maintenance. The Trouble Shooting Guide helps diagnose difficulties with cutter and offers solution to the problems.

Safety is of primary importance to the owner/operator and to the manufacturer. The first section of this manual includes a list of Safety Messages, that, if followed, will help protect the operator and bystanders from injury or death. Many of the Safety Messages will be repeated throughout the manual. The owner/operator/dealer should know these Safety Messages before assembly and be aware of the hazards of operating this rotary cutter during assembly, use, and maintenance. The Safety Alert Symbol combined with a Signal Word, as seen below, is intended to warn the owner/operator of impending hazards and the degree of possible injury faced when operating this machine.



Indicates an imminently hazardous situation that, if not avoided, WILL result in DEATH OR VERY SERIOUS INJURY.



Indicates an imminently hazardous situation that, if not avoided, COULD result in DEATH OR SERIOUS INJURY.



Indicates an imminently hazardous situation that, if not avoided, MAY result in MINOR INJURY.

Identifies special instructions or procedures that, if not strictly observed, could result in damage to, or destruction of the machine, attachments or the environment.

SAFETY SECTION

SAFETY SECTION

A safe and careful operator is the best operator. Safety is of primary importance to the manufacturer and should be to the owner/operator. Most accidents can be avoided by being aware of your equipment, your surroundings, and observing certain precautions. The safety section of this manual includes a list of guidelines that, if followed, will help protect the operator and bystanders from injury or death. READ, UNDERSTAND, and FOLLOW the following safety guidelines before assembling, operating or servicing this implement. Serious injury or death may occur unless care is taken to follow the warnings and instructions stated in these Safety guidelines. Practice all usual and customary safe working precautions and above all – remember safety is up to YOU.

Only YOU can prevent serious injury or death from unsafe practices.

This equipment should only be operated by those persons who have read the manual, who are responsible and trained, and who know how to do so safely and responsibly.

Si no lee ingles, pida ayuda a alguien que si lo lea para que le traduzca las medidas de seguridad.

General Safety Guidelines

- Never operate the tractor or implement until you have read and completely understand this manual and the tractor operator's manual. Learn how to stop the tractor engine suddenly in an emergency. Never allow inexperienced or untrained personnel to operate the tractor and implement without supervision. Make sure the operator has fully read and understood the manuals prior to operation.
- The operator and all support personnel should wear hard hats, safety shoes, safety glasses, and proper hearing protection at all times for protection from injury including injury from items that may be thrown by the equipment.
- Never allow children to operate, ride on, play on or around, or come close to the tractor or implement. Children can slip or fall off the equipment and be injured or killed. Usually, 16-17 year-old children who are mature and responsible can operate the implement with adult supervision, if they have read and understand the operator's manuals, been trained in proper operation of the tractor and implement, and are physically large enough to reach and operate the controls easily.
- NEVER use drugs or alcohol immediately before or while operating the tractor and implement. Drugs and alcohol will affect an operator's alertness and coordination and therefore affect the operator's ability to operate the equipment safely. Before operating the tractor or implement, an operator on prescription or over-the-counter medication must consult a medical professional regarding any side effects of the medication that would hinder their ability to operate the equipment safely. NEVER knowingly allow anyone to operate this equipment when their alertness or coordination is impaired. Serious injury or death to the operator or others could result if the operator is under the influence of drugs or alcohol.

SAFETY SECTION

- Prolonged tractor operation may cause operator boredom and fatigue affecting safe operation. Take scheduled work breaks to help prevent these potentially impaired operating conditions. Never operate the implement and tractor in a fatigued or bored mental state which impairs proper and safe operation.
- Tractors with or without an implement attached can often be noisy enough to cause permanent hearing loss. We recommend that you always wear hearing protection if the noise in the operator's position exceeds 80db. Noise over 85db over an extended period of time will cause severe hearing loss. Noise over 90db adjacent to the Operator over an extended period of time will cause permanent or total hearing loss.

Note: Hearing loss from loud noise [from tractors, chain saws, radios, and other such sources close to the ear] is cumulative over a lifetime without hope of natural recovery.

General Safety – Rotating Equipment

- The rotating parts of this machine continue to rotate even after the PTO has been turned off. The operator should remain in his seat for 60 seconds after the brake has been set, the PTO disengaged, the tractor turned off, and all evidence of rotation has ceased.
- Do not put hands or feet under implement decks. Blade contact can result in serious injury or even death. Stay away until all motion has stopped and the decks are securely blocked up.
- Do not operate the implement while wearing loose fitting clothing. Entanglement of the clothing with the rotating elements can result in serious injury or even death. KEEP AWAY FROM ROTATING ELEMENTS to prevent entanglement and possible serious injury or death.

General Safety – Hot Surfaces & Fire Safety

- Follow these guidelines to reduce the risk of equipment and grass fires while operating, servicing, and repairing the tractor and/or implement:
 - Equip the tractor with a fire extinguisher in an accessible location.
 - Do Not operate the implement on a tractor with an underframe exhaust.
 - Do Not smoke or have an open flame near the tractor and/or implement.
 - Do Not drive into burning debris or freshly burnt areas.
 - Ensure slip clutches are properly adjusted to prevent excessive slippage and plate heating.
 - Never allow clippings or debris to collect near drivelines, slip clutches, and gearboxes.
- Avoid contact with hot surfaces including hydraulic oil tanks, pumps, motors, valves and hose connections, engine or muffler. Relieve hydraulic pressure before performing maintenance or repairs. Use gloves and eye protection when servicing hot components. Contact with a hot surface or fluid can cause serious injury from burns or scalding.

SAFETY SECTION

Equipment Operation Safety

- All Safety Shields, Guards and Safety devices including (but not limited to) - the Deflectors, Chain Guards, Steel Guards, Gearbox Shields, PTO integral shields, and Retractable Door Shields should be used and maintained in good working condition.
- All safety devices should be inspected carefully at least daily for missing or broken components. Missing, broken, or worn items must be replaced at once. Broken or worn blades must be replaced with NEW blades to reduce the possibility of injury or death from thrown objects, entanglement, or blade contact. NEVER ATTEMPT TO STRAIGHTEN, WELD, OR WELD HARDFACING ON BLADES SINCE THIS WILL LIKELY CRACK OR OTHERWISE DAMAGE THE BLADE WITH SUBSEQUENT FAILURE AND POSSIBLE SERIOUS INJURY FROM THROWN BLADES.
- Operate the tractor and/or implement controls only while seated in the tractor seat with the seat belt securely fastened around you. Inadvertent movement of the tractor or implement may cause serious injury or death. Do not mount/dismount the tractor while the tractor or implement parts are moving. Mount the tractor only when the tractor and all moving parts are completely stopped.
- BEFORE leaving the tractor seat, always engage the brake and/or set the tractor transmission in parking gear, disengage the PTO, stop the engine, remove the key, and wait for all moving parts to stop. Place the tractor shift lever into a low range or parking gear to prevent the tractor from rolling. Never dismount a tractor that is moving or while the engine is running.
- Never leave the tractor and implement unattended while the implement is in the lifted position. Accidental operation of lifting lever or a hydraulic failure may cause sudden drop of unit possibly resulting in injury or death by crushing. Lower the implement carefully to the ground. Do not put hands or feet under lifted components.
- Do not exceed the rated PTO speed for the implement. Excessive PTO speeds can cause implement driveline or blade failures resulting in serious injury or death.
- Make sure the PTO shield, integral driveline shields, and input shields are installed when using PTO-driven equipment.
- DO NOT operate this implement on a tractor that is not properly maintained. In case of mechanical difficulty during operation, place the transmission in the park position, set the parking brake, shut down all power, including the PTO and the engine and remove the key. Wait until all rotating motion has stop before dismounting and perform repairs before resuming operation. Serious injury and possible death could occur from not maintaining this implement and tractor in good operating condition.
- Do not operate implement if excessive vibration exists. Shut down PTO and the tractor engine. Inspect the implement to determine the source of the vibration. If implement blades are missing

SAFETY SECTION

or damaged replace them immediately. Do not operate the implement until the blades have been replaced and the implement operates smoothly. Operating the implement with excessive vibration can result in component failure and broken objects to be thrown outward at very high velocities. To reduce the possibility of property damage, serious injury, or even death, never allow the implement to be operated with blades missing.

- Do not operate this equipment with hydraulic oil or fuel leaking. Oil and fuel are explosive and their presence could present a hazard. Do not check for leaks with your hand! High-pressure oil streams from breaks in the line could penetrate the skin and cause tissue damage.
- To check for a hose leak, SHUT the tractor ENGINE OFF and remove all hydraulic pressure. Wear oil impenetrable gloves, safety glasses and use cardboard to check for evidence of oil leaks.
- If you suspect a leak, REMOVE the HOSE and have it tested at a Dealer. If oil does penetrate the skin, have the injury treated immediately by a physician knowledgeable and skilled in this procedure. Always read carefully and comply fully with the manufacturer's instructions when handling oil, solvents, cleansers, and any other chemical agent.
- Mow at the speed that you can safely operate and control the tractor and implement. Safe mowing speed depends on terrain condition and grass type, density, and height of cut. Normal ground speed range is from 2 to 5 mph. Use slow mowing speeds when operating on or near steep slopes, ditches, drop-offs, overhead obstructions, power lines, or when debris and foreign objects are to be avoided.
- Avoid mowing in reverse direction when possible. Check to make sure there are no persons behind the implement and use extreme care when mowing in reverse. Mow only at a slow ground speed where you can safely operate and control the tractor and implement. Never mow an area that you have not inspected and removed debris or foreign material.
- The implement is designed for certain mowing applications and is rated to cut up to a specific size vegetation (see implement Standard equipment and Specifications). DO NOT use this implement to cut vegetation above the implement's rated capacity or to cut any type of non-vegetative material. Only operate this implement on a properly sized and equipped tractor. Operating this implement in an application for which it is not designed and/or operating the implement with the wrong size tractor can cause implement component damage and equipment failure resulting in possible serious injury or death.
- Do not operate or pull the implement into standing water. When uplift or fan type implement blades contact water they can be severely deflected downward causing possible failure of blade resulting in serious injury to the operator or bystanders.
- Do not mow with two machines in the same area except with cab tractors with the windows closed.

SAFETY SECTION

- Do not turn so sharp or lift implement so high to produce a severe “knocking” of the driveline which will cause accelerated wear and breakage of drive train components and could result in possible injury from the separated Driveline sections.
- Periodically shut down the tractor and implement and clean clippings and collected debris from the implement deck. DO NOT approach the implement unless the tractor is turned off and all motion has ceased.
- Never crawl under a raised implement supported solely by the tractor 3-Point hitch. Release of the control lever or mechanical failure will result in the implement falling and possible injury or death. Always securely block up the implement before crawling underneath to perform repairs and service. DO NOT allow any person under a folded wing unless wing is securely locked up or supported.

Equipment Operation Safety – Clearances and Obstructions

- Rotary implements are capable under adverse conditions of throwing objects for great distances (300 feet or more) and causing serious injury or death. Follow safety guidelines carefully.
- STOP MOWING IF PASSERSBY ARE WITHIN 100 YARDS
- Be sure you have adequate knowledge of the property you will be working on. Take time to make yourself aware of any area underground lines or cables. Always keep a careful lookout and use extreme care when working around utility and municipal obstructions. Never allow the implement to contact any utility, municipal, or other type structure. Clearly mark all mowing obstructions and consult local utility providers for a safe code of operation.
- Mow only in conditions where you have clear visibility in daylight or with adequate artificial lighting. Never mow in darkness or foggy conditions where you cannot clearly see at least 100 yards in front and to the sides of the tractor and implement. Make sure that you can clearly see and identify passersby, steep slopes, ditches, drop-offs, overhead obstructions, power lines, debris and foreign objects. If you are unable to clearly see these types of items discontinue mowing.
- This implement maybe wider than the tractor. Be careful when operating or transporting this equipment to prevent the implement from running into or striking sign posts, guard rails, concrete abutments or other solid objects. Such an impact could cause the implement and tractor to pivot violently resulting in loss of steering control, serious injury, or even death. Never allow the implement to contact obstacles.

SAFETY SECTION

- The rotating parts of this machine have been designed and tested thoroughly. However, the blades could fail upon impact with heavy, solid objects such as metal guard rails and concrete structures. Such impact could cause the broken objects to be thrown outward at very high velocities. To reduce the possibility of property damage, serious injury, or even death, never allow the cutting blades to contact such obstacles.
- Extreme care should be taken when operating near loose objects such as gravel, rocks, wire, and other debris. Inspect the area before mowing. Foreign objects should be removed from the site to prevent machine damage and/or bodily injury or even death. Any objects that cannot be removed must be clearly marked and carefully avoided by the operator. Stop mowing immediately if blades strike a foreign object. Repair all damage and make certain rotor or blade carrier is balanced before resuming mowing.
- This machine is often operated in heavy brush and in heavy weeds. The blades of this implement can throw objects if shields are not properly installed and maintained. Serious injury or even death may occur unless care is taken to insure the safety of the operator, bystanders, or passersby in the area. Do not operate this machine with anyone in the immediate area. Stop mowing if anyone is within 100 yards of implement.

Note: Where there are grass and weeds high enough to hide debris that could be struck by the blades, the area should be: inspected and large debris removed, mowed at an intermediate height, inspected, closely with any remaining debris being removed, and mowed again at desired final height. (This will also reduce power required to mow, reduce wear and tear on the implement drivetrain, spread cut material better, eliminate streaking, and make the final cut more uniform).

- Many varied objects, such as wire, cable, rope, or chains, can become entangled in the operating parts of the implement head. These items could then swing outside the housing at greater velocities than the blades. Such a situation is extremely hazardous and could result in serious injury or even death. Inspect the cutting area for such objects before mowing. Remove any like object from the site. Never allow the cutting blades to contact such items.
- Do not let the blades turn when the implement deck is raised for any reason, including clearance or for turning. Raising the implement deck exposes the cutting blades which creates a potentially serious hazard and could cause serious injury or even death from objects thrown from the blades.
- Do Not operate this equipment in areas where insects such as bees may attack you and/or cause you to lose control of the equipment. If you must enter in such areas, use a tractor with an enclosed cab and close the windows to prevent insects from entering. If a tractor cab is not available, wear suitable clothing including head, face, and hand protection to shield you from the insects. Attacking insects can cause you to lose control of the tractor, which can result in serious injury or death to you or bystanders. Never dismount a moving tractor.

SAFETY SECTION

Connecting or Disconnecting Implement Safety

- Always shut the tractor completely down, place the transmission in park, and set the parking brake before you or anyone else attempts to connect or disconnect the implement and tractor hitches.
- DO NOT use a PTO adapter to attach a non-matching implement driveline to a tractor PTO. Use of an adapter can double the operating speed of the implement resulting in excessive vibration, thrown objects, and blade and implement failure. Adapter use will also change the working length of the driveline exposing unshielded driveline areas. Serious bodily injury and/or equipment failure can result from using a PTO adapter. Consult an authorized dealer for assistance if the implement driveline does not match the tractor PTO.
- When attaching the implement input driveline to the tractor PTO, it is important that the connecting yoke spring activated locking collar slides freely and the locking balls are seated securely in the groove on the tractor PTO shaft. A driveline not attached correctly to the tractor PTO shaft could come loose and result in personal injury and damage to the implement.
- Before operating the implement, check to make sure the implement input driveline will not bottom out or become disengaged. Bottoming out occurs when the inner shaft penetrates the outer housing until the assembly becomes solid-it can shorten no more. Bottoming out can cause serious damage to the tractor PTO by pushing the PTO into the tractor and through the support bearings or downward onto the PTO shaft, breaking it off. A broken drive line can cause personal injury.

SAFETY SECTION

Transporting Safety

- Only tow the implement behind a properly sized and equipped tractor which exceeds the weight of the implement by at least 20%. DO NOT tow the implement behind a truck or other type of vehicle. Never tow the implement and another implement connected in tandem.
- Make certain before transporting that a "Slow Moving Vehicle" (SMV) sign is installed in such a way as to be clearly visible and legible. When transporting the implement use the tractor flashing warning lights and follow all local traffic regulations.
- Your driving vision may be reduced or impaired by the tractor, cab, or implement. Before driving on public roadways identify any limited vision areas, and make adjustments to your operating position, mirrors, and the implement transport position so that you can clearly see the area where you will be traveling, and any traffic that may approach you. Failure to maintain adequate vision of the public roadway and traffic can result in serious injury or even death.
- Understand the tractor and implement and how it handles before transporting on streets and highways. Make sure the tractor steering and brakes are in good condition and operate properly.
- Transport only at speeds where you can maintain control of the equipment. Serious accidents and injuries can result from operating this equipment at high speeds. Before transporting the tractor and implement, determine the proper transport speeds for you and the equipment. Make sure you abide by the following rules:
 - Test the tractor at a slow speed and increase the speed slowly. Apply the Brakes smoothly to determine the stopping characteristics of the tractor and implement. As you increase the speed of the tractor the stopping distance increases. Determine the maximum transport speed not to exceed 20 mph (30 kph) for towing this equipment.
 - Test the equipment at a slow speed in turns. Increase the speed through the turn only after you determine that it is safe to operate at a higher speed. Use extreme care and reduce your speed when turning sharply to prevent the tractor and implement from turning over. Determine the maximum safe turning speed for you and this equipment before operating on roads or uneven ground.

SAFETY SECTION

- Be aware of the operating conditions. Do not operate the tractor with weak or faulty brakes or worn tires. When operating down a hill or on wet or rain slick roads, the braking distance increases: use extreme care and reduce your speed. When operating in traffic always use the tractor's flashing warning lights and reduce your speed. Be aware of traffic around you and watch out for the other guy.
- Turn curves or go up hills only at a low speed and using a gradual steering angle. Rear mounted implements move the center of gravity to the rear and remove weight from the front wheels. Make certain, by adding front ballast, that at least 20% of the tractor's weight is on the front wheels to prevent rearing up, loss of steering control or tractor tip-over.
- Slow down on rough or uneven surfaces to prevent loss of steering control which could result in property damage or possible injury. Do not transport unless 3-Point lift lever is fully raised and in the latched transport position. Dropping implement in transport can cause serious damage to the tractor and/or implement and possibly cause the operator or others to be injured or killed.
- In wet conditions where there is a likelihood of material collecting on the implement, make certain that excess material is removed before traveling on public roadways.
- Allow sufficient clearance for the implement to swing outward while turning. Implements carried behind the tractor will swing outside the tire path when making turns. Contacting a solid object while turning will cause equipment damage and possible injury.

Maintenance and Service Safety

- Periodically inspect all moving parts for wear and replace when necessary with authorized service parts. Look for loose fasteners, worn or broken parts, and leaky or loose fittings. Make sure all pins have cotter pins and washers. Serious injury may occur from not maintaining this machine in good working order.
- Perform service, repairs and lubrication according to the maintenance section. Ensure the unit is properly lubricated as specified in the lubrication schedule and all bolts and nuts have proper torque. Failure to properly service, repair and maintain this implement in good operating condition could cause component failure and possible serious injury or even death.
- Use extreme caution when getting onto the implement to perform repairs, maintenance and when removing accumulated material. Only stand on solid flat surfaces to ensure good footing. Slipping and falling can cause serious injury or death.

SAFETY SECTION

Maintenance and Service Safety Continued

- Never work under the implement, the framework, or any lifted component unless the implement is securely supported or blocked up to prevent sudden or inadvertent falling which could cause serious injury or even death.
- Never attempt to lubricate, adjust, or remove material from the implement while it is in motion or while tractor engine is running. Make sure the tractor engine is off, the transmission in park, the parking brake set, and that the key is with you before working on the implement.
- Always disconnect the main PTO Driveline from the tractor before performing service on the implement. Never work on the implement with the tractor PTO driveline connected and running. Rotating Parts, blades or drivelines could turn without warning and cause immediate entanglement, injury or death.
- DO NOT weld or repair rotating implement components. Welds and other repairs may cause severe vibration and/or component failure resulting in part being thrown from the implement causing serious bodily injury. See your Authorized Dealer for proper repair procedures.
- DO NOT weld or perform hot work on galvanized implements. Heating/burning of galvanizing material may release fumes which can be harmful to your health. (If applicable)
- Do not modify or alter this implement. Do not permit anyone to modify or alter this implement, any of its components or any implement function.

SAFETY SECTION

Parts Information

- Modern Ag implements use balanced and matched system components for blade carriers, blades, cuttershafts, knives, knife hangers, rollers, drivetrain components, and bearings. These parts are made and tested to Modern Ag specifications. Always replace blades with original equipment manufacturer balanced blade sets. Non-genuine “will fit” parts do not consistently meet these specifications. The use of “will fit” parts may reduce implement performance, void warranties, and present a safety hazard. Use genuine Modern Ag implement parts for economy and safety.

Safety Signs/Decals

- Modern Ag supplies safety decals on this product to promote safe operation. Damage to the decals may occur while in shipping, use, or reconditioning. Always maintain the safety signs in good readable condition. If the safety signs are missing, damaged, or unreadable, obtain and install replacement safety signs immediately.

Concluding Safety Instructions and Practices

- In addition to the design and configuration of this implement, including safety signs and safety equipment, hazard control and accident prevention are dependent upon the awareness, concern, prudence, and proper training of personnel involved in the operation, transport, maintenance, and storage of the machine. Refer also to safety guidelines and operation instruction in each of the appropriate sections of the tractor and equipment manuals. Pay close attention to the Safety Signs affixed to the tractor and equipment.

8' SAFETY DECAL LOCATIONS

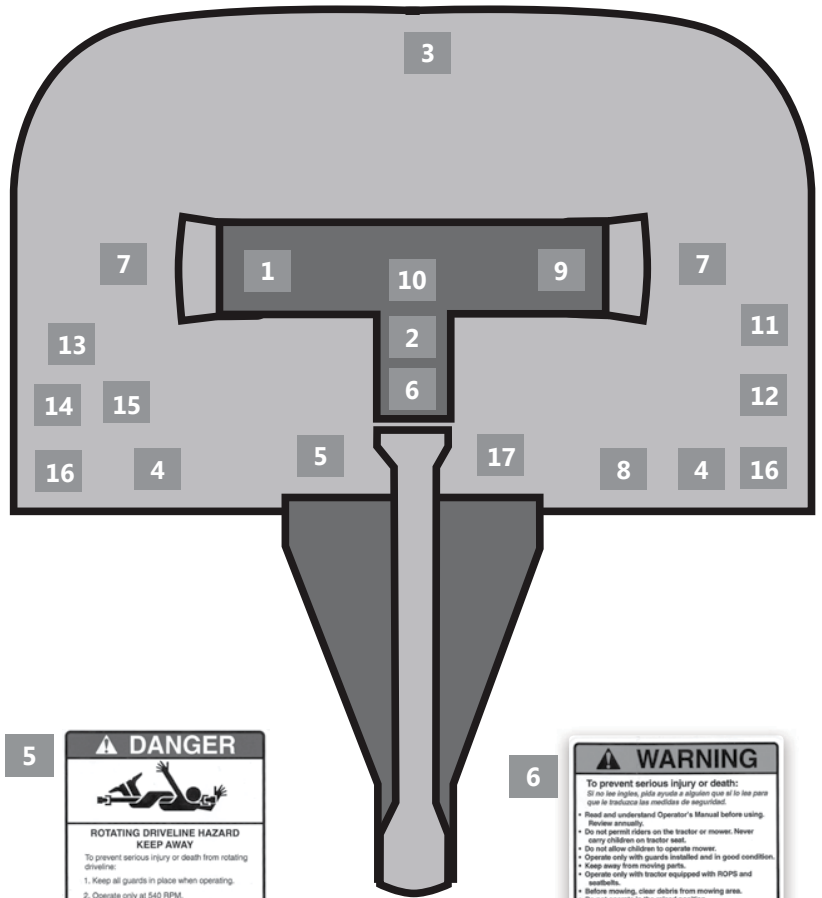

1

⚠ DANGER

Do not attach this implement or attempt to operate until you have read and understood all instructions in the owner's manual. If an owner's manual is not available, contact Modern, Inc. 1655 Louisiana St., Beaumont, TX 77701; or call 800-231-8198. (Si no entiende ingles, se prefiere que busque alguien que interprete las instrucciones para usted.) 495-0119

2

ATTENTION

GEARBOXES ARE FILLED WITH EP 90 LUBRICANT BUT MUST BE VERIFIED BEFORE UNIT IS PUT INTO SERVICE

3

⚠ DANGER

THROWN OBJECT HAZARD
To prevent serious injury or death:

- Do not operate unless all guards are installed and in good condition.
- Stop blade rotation if bystanders come within several hundred feet.

38000

4

⚠ DANGER

ROTATING BLADES-KEEP AWAY
To prevent serious injury or death when the engine is running and the blades are rotating:

- Never allow riders, especially children, on tractor or mower.
- Do not operate with bystanders in mowing area.
- Do not operate with deflector/guards removed.
- Do not place hands or feet under deck.

38000

5

⚠ DANGER

ROTATING DRIVELINE HAZARD KEEP AWAY
To prevent serious injury or death from rotating driveline:

- Keep all guards in place when operating.
- Operate only at 540 RPM.
- Keep hands, feet, clothing and hair away from moving parts.

0113

6

⚠ WARNING

To prevent serious injury or death:
Si no lee ingles, pida ayuda a alguien que se lo lee para que le traduzca las medidas de seguridad.

- Read and understand Operator's Manual before using. Review annually.
- Do not permit riders on the tractor or mower. Never carry children on tractor seat.
- Do not allow children to operate mower.
- Operate only with guards installed and in good condition.
- Keep away from moving parts.
- Operate only with tractor equipped with ROPS and seatbelts.
- Before mowing, clear debris from mowing area.
- Do not operate in the raised position.
- Stop engine, set brake and wait for all moving parts to stop before dismounting.
- Support mower securely before working beneath unit.
- Transport with clean reflectors, SBV and working lights as required by federal, state, and local laws.

38000

7

⚠ CAUTION

KEEP HANDS CLEAR

8

⚠ CAUTION

GALVANIZED COATING
WELDING OR TORCHING MAY PRODUCE FUMES AND GASES HAZARDOUS TO YOUR HEALTH. AVOID BREATHING THESE FUMES AND GASES.
USE ADEQUATE VENTILATION
ANY QUESTIONS - CONTACT YOUR DEALER

9

⚠ DANGER

REPLACE SHIELDS BEFORE USING MACHINE

495-0309

10

RE-TORQUE GEARBOX NUTS EVERY 40 HOURS

11

MODERN AG
YEAR LIMITED GEARBOX WARRANTY

12

10 YEAR DECK WARRANTY
60 GALVANIZED
10 YEAR LIMITED GALVANIZED RUST THRU WARRANTY

13

MADE IN THE USA
SINCE 1947
MODERN AG

14

MADE IN USA

15

FEMA
FARM EQUIPMENT MANUFACTURERS ASSOCIATION

16

P08

17

MODERN AG
SINCE 1947

ADDITIONAL CUTTER DECALS

ITEM	PART NO.	DESCRIPTION	QTY.
.....	490-9000.....	Completed Decal Sheet.....	1
1.....		Do Not Attach.....	1
2.....		Lubricate Gearbox.....	1
3.....		Thrown Objects.....	1
4.....		Rotating Blades.....	1
5.....		Rotating Driveline.....	1
6.....		Warning to Prevent Injury.....	1
7.....	490-1024.....	Keep Hands Clear.....	1
8.....	490-GALVCOAT.....	Caution: Galvanized Coating.....	1
9.....	490-5009.....	Replace Shields.....	1
10.....	490-2010.....	Retorque Gearbox.....	1
11.....	490-2213.....	Gearbox Warranty.....	1
12.....	490-2216.....	Deck Rust Warranty.....	1
13.....	490-2211.....	Modern Ag Shield.....	1
14.....	490-1023.....	Made in USA.....	1
15.....	490-FEMA.....	FEMA Member.....	1
16.....	490-1132.....	P08 Decal.....	1
17.....	490-2220.....	MODERN Decal.....	1

OPERATION SECTION

OPERATION SECTION

OPERATION INSTRUCTIONS

Our rotary cutters are manufactured with quality material by skilled workers. These cutters are designed to cut grass, weeds, crop stalks, brush and other vegetation up to 3" diameter. The cutter is equipped with protective deflectors and/or chain guards to prevent objects being thrown from the cutter by the blades, however, no shielding is 100% effective. All shields, guards, deflectors, and chains equipped on the unit must be maintained on the cutter in good operational condition.

It is the operator's responsibility to be knowledgeable of all potential operating hazards and to take every reasonable precaution to ensure oneself, others, animals, and property are not injured or damaged by the cutter, tractor, or a thrown object. Do not operate the cutter if passersby, pets, livestock, or property are within 300 feet of the unit.

This section of the Operator's Manual is designed to familiarize, instruct, and educate safe and proper cutter use to the operator. Pictures contained in this section are intended to be used as a visual aid to assist in explaining the operation of a single spindle cutter and are not necessarily of all cutters. Some pictures may show shields removed for picture clarity. NEVER OPERATE this implement without all shields in place and in good operational condition. The operator must be familiar with the cutter and tractor operation and all associated safety practices before operating the cutter and tractor. Proper operation of the cutter, as detailed in this manual, will help ensure years of safe and satisfactory use of the cutter.

IMPORTANT: To avoid cutter damage, retorque all bolts after the first 10 hours of operation. Retighten blade carrier retaining nut on gearbox lower shafts to 450 ft. lbs.

READ AND UNDERSTAND THE ENTIRE OPERATING INSTRUCTIONS AND SAFETY SECTION OF THIS MANUAL AND THE TRACTOR MANUAL BEFORE ATTEMPTING TO USE THE TRACTOR AND Cutter. If you do not understand any of the instructions, contact your nearest authorized dealer for a full explanation. Pay close attention to all safety signs and safety messages contained in this manual and those affixed to the cutter and tractor.

READ, UNDERSTAND, and FOLLOW the following Safety Messages. Serious injury or death may occur unless care is taken to follow the warnings and instructions stated in the Safety Messages. Always use good common sense to avoid hazards.



Si no lee ingles, pida ayuda a alguien que si lo lea para que le traduzca las medidas de seguridad.

OPERATION SECTION

8' PREDATORRR CUTTER STANDARD **EQUIPMENT AND SPECIFICATIONS**

Cutting Width 96"
Transport Width 102"
Overall Width..... 102"
Overall Length..... 97"
Overall Height..... 2"-15"
Blade Overlap 3"
Jackstand Standard
Hitch Cat. II or Clevis
Blade Carrier Pan Stump Jumpers
PTO Horespower Required (min) . 45 HP
Gearbox Rating:*
Main Gearbox or Divider Box .. 150 HP
Outboard Gearbox or Center
& Wings 95 HP
Output Shaft Diameter 2-3/8"
Cut Capacity..... 3"
Blade Tip Speed:
540..... 14.482 FPM
1000 14.396 FPM
Driveline Size:
Pull Type:
Pull-Cat. 5 CV w/Slip Clutch
3pt. Lift Type 3pt.-Cat 4 w/Clutch
Deck Thickness 3/16"
Side Skirt 1/4" x 8"
Front Safety Deflectors Chain Option
Rear Safety Deflectors:
Rubber Guard Standard with Chain Option
Weight (Aprrox).....
3PT..... 1875 Lbs
Pull..... 2370 Lbs
Tires..... Laminated 600x9
Dual Tailwheels (Pull Type) Option
Hydraulic Level Lift (Pull Type)... Standard

****Safety Deflectors are standard equipment. Single and double chain guards are available as extra equipment at extra cost. Modern recommends cutters be equipped with deflectors or double chain guards for all mowing purposes. Single chain guards may be used for agriculture purposes only and are specifically not recommended for highway, right-of-way, parks or greenbelt mowing.***

*****Ratings based on actual field performance.***

OPERATION SECTION

OPERATOR REQUIREMENTS

Safe operation of the unit is the responsibility of a qualified operator. A qualified operator has read and understands the implement and tractor Operator's Manuals and is experienced in implement and tractor operation and all associated safety practices. In addition to the safety messages contained in this manual, safety decals are affixed to the implement and tractor. If any part of the operation and safe use of this equipment is not completely understood, consult an authorized dealer for a complete explanation.

If the operator cannot read the manuals for themselves or does not completely understand the operation of the equipment, it is the responsibility of the supervisor to read and explain the manuals, safety practices, and operating instructions to the operator.

Safe operation of equipment requires that the operator wear approved Personal Protective Equipment (PPE) for the job conditions when attaching, operating, servicing, and repairing the equipment. PPE is designed to provide operator protection and includes the following safety wear:

PERSONAL PROTECTIVE EQUIPMENT (PPE)

- Protective Eye Glasses, Goggles, or Face Shield
- Hard Hat
- Steel Toe Safety Footwear
- Gloves
- Hearing Protections
- Close Fitting Clothing
- Respirator or Filter Mask
(depends on mowing conditions)

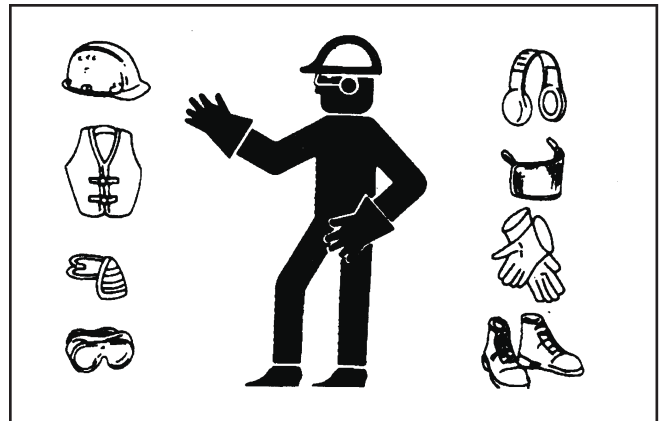

DANGER

NEVER use drugs or alcohol immediately before or while operating the Tractor and Implement. Drugs and alcohol will affect an operator's alertness and coordination and therefore affect the operator's ability to operate the equipment safely. Before operating the Tractor or Implement, an operator on prescription or over-the-counter medication must consult a medical professional regarding any side effects of the medication that would hinder their ability to operate the Equipment safely. NEVER knowingly allow anyone to operate this equipment when their alertness or coordination is impaired. Serious injury or death to the operator or others could result if the operator is under the influence of drugs or alcohol.

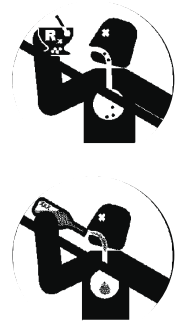

OPERATION SECTION

TRACTOR REQUIREMENTS

The tractor used to operate the cutter must have the power capacity to lift, pull, and operate the Power Take Off (PTO) at the cutter's rated speed while traveling at a ground speed between 2 and 5 MPH. Operating the cutter with a tractor that does not meet the following requirements may cause tractor or cutter damage and be a potential danger to the operator and passersby.

ROPS and Seat Belt

The tractor must be equipped with a Roll-Over-Protective-Structure (ROPS) (tractor cab or roll-bar) and seat belt to protect the operator from falling off the tractor, especially during a roll over where the driver could be crushed and killed. Only operate the tractor with the ROPS in the raised position and seat belt fastened. Tractor model not equipped with a ROPS and seat belt should have these life saving features installed by an authorized dealer.



Operate this Equipment only with a Tractor equipped with an approved rollover-protective system (ROPS). Always wear seat belts. Serious injury or even death could result from falling off the tractor--particularly during a turnover when the operator could be pinned under the ROPS.

Tractor Safety Devices

If transporting or operating the tractor and cutter near a public roadway, the tractor must be equipped with proper warning lighting and a Slow Moving Vehicle (SMV) emblem which are clearly visible from the rear of the unit. Lights and a SMV emblem must be equipped directly on implements if the visibility of the tractor warning signals are obscured. Maintain all manufacturer equipped safety shields and guards. Always replace shields and guards that were removed for access to connect, service, or repair the tractor or cutter. Never operate the tractor PTO with the PTO master shield missing or in the raised position.

*Ratings are based upon field performance.

OPERATION SECTION

DANGER

DO NOT use a PTO adapter to attach a non-matching Implement driveline to a Tractor PTO. Use of an adapter can double the operating speed of the Cutter resulting in excessive vibration, thrown objects, and blade and cutter failure. Adapter use will also change the working length of the driveline exposing unshielded driveline areas. Serious bodily injury and/or equipment failure can result from using a PTO adapter. Consult an authorized dealer for assistance if the Implement driveline does not match the Tractor PTO.

WARNING

Never operate the Tractor and Cutter if the Implement input driveline is directly connected to the Tractor transmission. Tractor braking distances can be substantially increased by the momentum of the rotating Cutter blades driving the Tractor transmission even though the Tractor clutch has been disengaged. Install an over running clutch between the Tractor PTO and the Cutter driveline to prevent this potentially dangerous situation.

Tire Spacing

Refer to the tractor Operator's Manual or consult an authorized dealer for instructions to change tractor tire spacing.

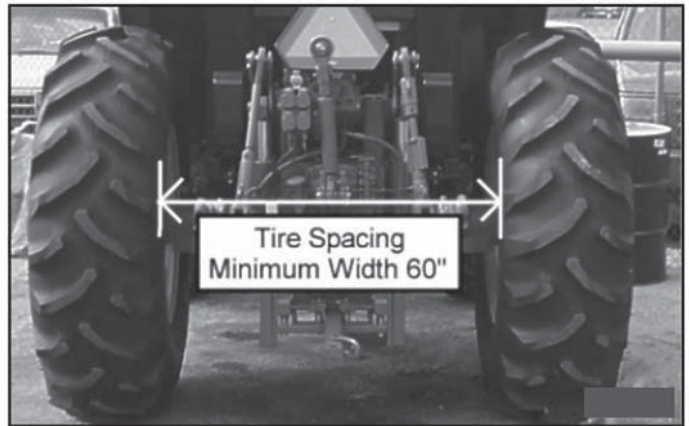

GETTING ON AND OFF THE TRACTOR

Before getting onto the tractor, the operator must read and completely understand the implement and tractor operator manuals. If any part of either manual is not completely understood, consult an authorized dealer for a complete explanation.

WARNING

Do not mount the Tractor while the tractor is moving. Mount the Tractor only when the Tractor and all moving parts are completely stopped.

OPERATION SECTION

Tractor Horsepower

The power required to operate a cutter is determined by the tractor PTO horsepower. Operating the cutter with a tractor that does not have adequate power may damage the tractor engine.

3-Point Hitch

The tractor 3-point hitch must be rated to lift at least 1000 lbs.

Refer to the tractor operator's manual for the category of the tractor being used. If the hitch does not conform to ASAE dimensions, the cutter may not fit or raise properly.

Depending on the hitch category, certain size pins are used to attach the cutter to the tractor. CAT I hitches require 7/8" lower and 3/4" upper diameter hitch pins.

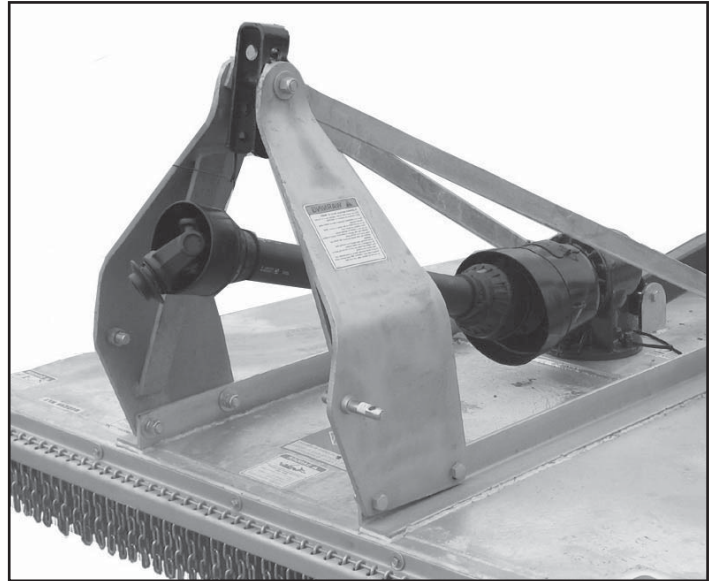

Front End Weight

A minimum of 20% total tractor weight must be maintained on the tractor front end at all times.

Front end weight is critical to maintain steering control and to prevent the tractor from rearing up while driving. If the front end is too light, add weight until a minimum of 20% total weight is reached on the front tires. Front weights and weight carriers can be purchased through an authorized tractor dealership.

Power Take Off (PTO)

This cutter is designed to operate at a PTO speed of 540. Most tractors operate at either 540, or a combination of 540 and 1000 RPM PTO speeds. The operating speed of the cutter and tractor can be determined by the number of splines on the driveline yoke and PTO output shaft. Those operating at 540 RPM will have a 6-spline shaft and those operating at 1000 RPM will have a 21-spline shaft.

If operating an older model tractor where the tractor's transmission and PTO utilize one master clutch, an over-running clutch must be used between the PTO output shaft and the driveline of the cutter. An authorized tractor dealer can provide the over-running clutch and its installation if needed.

OPERATION SECTION

Boarding the Tractor

Use both hands and equipped handrails and steps for support when boarding the tractor. Never use control levers for support when mounting the tractor. Seat yourself in the operator's seat and secure the seat belt around you.

Never allow passengers to ride on the tractor or attached equipment. Riders can easily fall off and be seriously injured or killed from falling off and being run over. It is the operator's responsibility to forbid all extra riders at all times.



Never allow children to operate, ride on, or come close to the Tractor or Implement. Usually, 16-17 year-old children who are mature and responsible can operate the implement with adult supervision, if they have read and understand the Operator's Manuals, been trained in proper operation of the tractor and Implement, and are physically large enough to reach and operate the controls easily.



Never allow children or other persons to ride on the Tractor or Implement. Falling off can result in serious injury or death.

Dismounting the Tractor

Before dismounting, park the tractor and implement on a reasonably level surface, apply the parking brake, idle the engine down, disengage the PTO, and lower the implement to the ground. Shut down the tractor engine according to the operator's manual, remove the key, and wait for all motion to completely stop. Never leave the seat until the tractor, its engine and all moving parts have come to a complete stop.

Use hand rails and steps when exiting the tractor. Be careful of your step and use extra caution when mud, ice, snow or other matter has accumulated on the steps or hand rails. Use all handrails and steps for support and never rush or jump off the tractor.



BEFORE leaving the tractor seat, always engage the brake and/or set the tractor transmission in parking gear, disengage the PTO, stop the engine, remove the key, and wait for all moving parts to stop. Place the tractor shift lever into a low range or parking gear to prevent the tractor from rolling. Never dismount a Tractor that is moving or while the engine is running. Operate the Tractor controls from the tractor seat only.

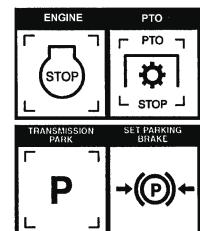

OPERATION SECTION

CONNECTING THE CUTTER TO THE TRACTOR

Use extreme caution when connecting the cutter to the tractor. The cutter should be securely resting at ground level or setting on blocks. Keep hands and feet from under the cutter deck and clear of pinch points between the tractor hitch arms and cutter pins.



DANGER

Always shut the Tractor completely down, place the transmission in park, and set the parking brake before you or anyone else attempts to connect or disconnect the Implement and Tractor hitches.

Connecting Cutter-Lift Type

1. Make sure the tractor is equipped with the correct PTO shaft. Change shafts if needed.
2. Shorten or remove the tractor drawbar to avoid interference when raising and lowering the cutter.
3. Board the tractor and start the engine. Position the tractor to the cutter with the 3-point lift arms positioned at the same height and to the outside of the cutter hitch pins.
4. Turn off the tractor engine and dismount.
5. One lift arm at a time, align arm end hole with the A frame lift pins. Mount lift arms on lift pin and retaining pin into hitch pin.
6. Walk around to opposite side and repeat procedure for remaining lift arm and hitch pin.
7. Extend or retract 3-point top link to align its end hole with the holes of the cutter's top link. Insert the top link hitch pin and insert retaining pin into hitch pin.
8. Adjust any lower link check chains, guide blocks, or sway blocks to prevent the cutter from swaying side to side and possible contact with tractor rear tires.



NOTE: Set the 3-point lift control to "Position Control" so that the lift arms maintain a constant height when attaching the cutter. See the tractor Operator's Manual for correct settings when attaching 3-point equipment

SAFETY CHAINS

When towing implements on a public roadway, use a safety chain with tensile strength equal to or greater than the gross weight of the unit being towed. This will control the implement in the event the hitch pin is lost during transport.

After the ends of the safety chain are attached to the implement and the tractor, make a trial run by driving the tractor to the right and to the left.

SETTING THE CUTTER

Properly setting the cutting height is essential for efficient and safe operation. A properly set cutter will make a more uniform cut, distribute clippings more evenly, require minimal tractor work, and follow the contour of uneven terrain.

NOTE: Avoid very low cutting heights, striking the ground with the blades gives the most damaging shock loads and will cause damage to the cutter and drive. Blades contacting the ground may cause objects to be thrown out from under the cutter deck. Always avoid operating the cutter at a height which causes the blades to contact the ground.



Never work under the Implement, the framework, or any lifted component unless the Implement is securely supported or blocked up to prevent sudden or inadvertent falling which could cause serious injury or even death.

Setting Cutter Height - Lift Type

1. Park the tractor and cutter on level ground.
2. Using the 3-point hitch control lever, position the front of the cutter with the side skids 1" less off the ground than desired cut height. For example, for a 3" cut, position the skids 2" from the ground. Set the 3-point control lever stop at this position to maintain this height when raising and lowering the cutter.
3. Shut down the tractor and remove the key.
4. Adjust the cutter deck front to rear by extending or retracting the 3-point top link. Always set front of deck 3/4" lower than rear for best performance.
5. Level the cutter side to side by manipulating one lower lift arm length. On most tractors, at least one of the lift arms is designed to allow for manipulation of its length. Shortening or extending will allow for deck leveling from side to side.
6. Securely block up the cutter at this height.
7. Remove the bolts securing the tailwheel beam in position and allow the tailwheel to rest at ground level. Align tailwheel beam between nearest sets of holes in beam support brackets and reinstall support bolts on each side of beam. Tighten all bolts and nuts.
8. Extend the tractor's top 3-point link so that when lifting the cutter, the front of the deck will raise 2 to 2½" before the tail wheel leaves the ground. This will allow the cutter to follow the contour of uneven terrain.

OPERATION SECTION

SETTING THE CUTTER

Properly setting the cutting height is essential for efficient and safe operation. A properly set cutter will make a more uniform cut, distribute clippings more evenly, require minimal tractor work, and follow the contour of uneven terrain.

NOTE: Avoid very low cutting heights, striking the ground with the blades gives the most damaging shock loads and will cause damage to the cutter and drive. Blades contacting the ground may cause objects to be thrown out from under the cutter deck. Always avoid operating the cutter at a height which causes the blades to contact the ground.



Never work under the Implement, the framework, or any lifted component unless the Implement is securely supported or blocked up to prevent sudden or inadvertent falling which could cause serious injury or even death.

Setting Cutter Height - Pull Type

1. Place the tractor and mower on a level surface.
2. Using the hydraulic cylinder, position the mower so the skid shoes are 1" less off the ground than the desired final cut height. For example, for a 3" cut raise or lower the mower until the skid shoes are approximately 2" off the ground.
3. Shut down the tractor, place the transmission in park and set the parking brake before dismounting.
4. Level the mower deck front to rear by adjusting the leveling rods linking the tongue to the rear axle. DO NOT allow feet or other body parts underneath the mower when making adjustments. To adjust rod length, screw turnbuckle. To lower the front, lengthen the rods and to raise the front, shorten the rods.
DO NOT unscrew turnbuckles to the point that either rod threaded ends becomes disconnected which will cause mower to fail.
IMPORTANT: Alternate adjustments between rods and adjust at equal lengths to maintain equal tension. Improper adjustments may cause rods to snap or bend.
5. Place split collar assemblies on the hydraulic cylinder rod to maintain a set cutting height each time the mower is raised and lowered.

OPERATION SECTION

STARTING THE TRACTOR

The operator must have a complete understanding of the placement, function, and operational use of all tractor controls before starting the tractor. Review the tractor operator's manual and consult an authorized dealer for tractor operation instructions if needed.

Essential Tractor Controls:

- Locate the light control lever.
- Locate the engine shut off control.
- Locate the brake pedals and the clutch.
- Locate the PTO control.
- Locate the 3-point hitch control lever.
- Locate the hydraulic remote control levers.

Before starting the tractor ensure the following:

- Conduct all pre-start operation inspection and service according to the tractor operator's manual.
- Make sure all guards, shields, and other safety devices are securely in place.
- The parking brake is on.
- The PTO control lever is disengaged.
- The 3-point hitch control lever is in the lowered position.
- The hydraulic remote control levers are in the neutral position.
- The tractor transmission levers are in park or neutral.

Refer to the tractor owner's manual for tractor starting procedures. Only start the tractor while seated and belted in the tractor operator's seat. Never bypass the ignition switch by short circuiting the starter solenoid. After the tractor engine is running, avoid accidental contact with the tractor transmission to prevent sudden and unexpected tractor movement.



Never run the Tractor engine in a closed building or without adequate ventilation. The exhaust fumes can be hazardous to your health.

Start tractor only when properly seated in the Tractor seat. Starting a tractor in gear can result in injury or death. Read the Tractor operators manual for proper starting instructions.



CONNECTING THE CUTTER TO THE TRACTOR

Use extreme caution when connecting the cutter to the tractor. The cutter should be securely resting at ground level or setting on blocks. Keep hands and feet from under the cutter deck and clear of pinch points between the tractor hitch arms and cutter pins.



Always shut the Tractor completely down, place the transmission in park, and set the parking brake before you or anyone else attempts to connect or disconnect the Implement and Tractor hitches.

OPERATION SECTION

DRIVELINE ATTACHMENT

The driveline yoke and tractor PTO shaft must be dirt free and greased for attachment.

To connect the cutter driveline to the tractor PTO output shaft, pull the driveline yoke collar back and align the grooves and splines of the yoke with those of the PTO shaft. Push the driveline yoke onto the PTO shaft, release the locking collar, and position the yoke until the locking collar balls are seated onto the PTO shaft. Push and pull the driveline back and forth several times to ensure a secure attachment.

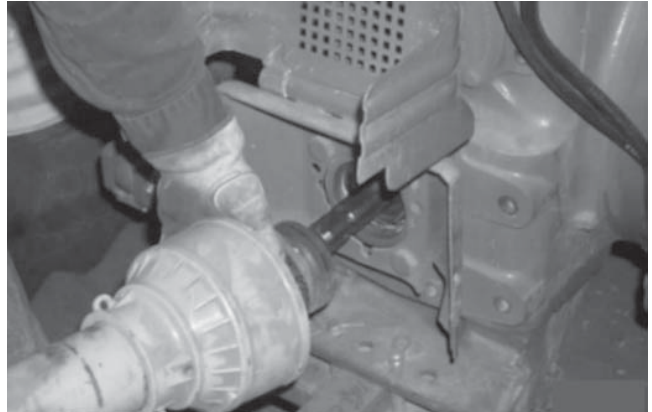

DANGER

When attaching the Implement input driveline to the Tractor PTO, it is important that the connecting yoke spring activated locking collar slides freely and the locking balls are seated securely in the groove on the Tractor PTO shaft. A driveline not attached correctly to the Tractor PTO shaft could come loose and result in personal injury and damage to the implement.

The operator's manual and decals affixed on the unit contain important instructions on the safe and proper use of the equipment. Maintain these important safety features on the implement in good condition to ensure the information is available to the operator at all times.

- Ensure the manual canister is secured to the equipment with the operator's manual inside.
- Ensure all decals are in place and legible. Replace missing, damaged, and illegible decals.
- Ensure the cutter hitch is securely attached to the tractor drawbar with a proper size bolt and secured nut.
- Ensure chain guards and/or rubber deflectors are in position and not damaged. Replace worn, broken, and missing sections immediately.
- Ensure the driveline integral shields are in good condition and rotate freely.
- Inspect that all bolts and screws are in position and are properly torqued.

- Ensure the tractor PTO master shield is in place, lowered and in good condition.
- Ensure each cutter slip clutch shield is secured in place and in good condition.
- Inspect each gearbox oil level and replenish if needed. A low oil level is a warning sign that the gearbox may be cracked or its seal is damaged and needs to be replaced.
- Ensure all gearbox vents are in place and free from clogs.
- Inspect blades and blade bolts for looseness and excessive wear. Make sure the cutter is securely blocked up before crawling beneath. Replace damaged, worn, and missing blades as complete sets to maintain rotary balance.
- Ensure carrier hub nuts are tightened with the cotter pin inserted and spread.

OPERATION SECTION

Tractor Pre-Operation Inspection/Service

Refer to the tractor operator's manual to ensure a complete pre-operation inspection and scheduled service is performed according to the manufacturers recommendations. The following are some of the items that require daily service and inspection:

- Tire condition/air pressure
- Wheel lug bolts
- Steering linkage
- PTO shield
- SMV sign is clean and visible
- Tractor's lights are clean and functional
- Tractor Seat belt is in good condition
- Tractor ROPS is in good condition
- ROPS is in the raised position
- No tractor oil leaks
- Radiator free of debris
- Engine oil level and condition
- Engine coolant level and condition
- Power brake fluid level
- Power steering fluid level
- Fuel condition and level
- Sufficient lubrication at all lube points
- Air filter condition

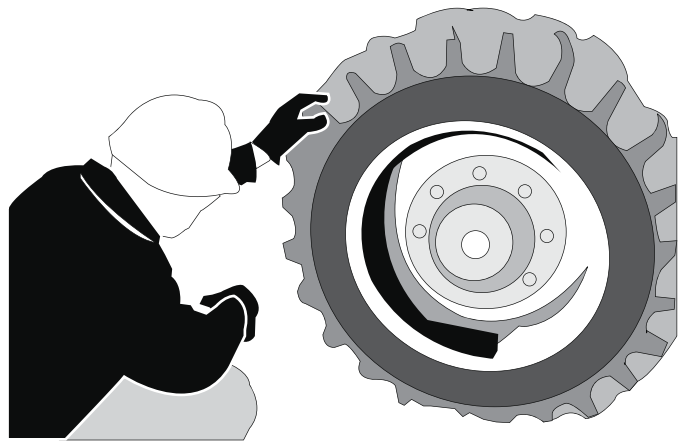

Cutter Pre-Operation Inspection/Service

Before each cutter use, a complete inspection and service is required to ensure the cutter is in a good and safe working condition. Damaged and/or broken parts should be repaired and/or replaced immediately. To ensure the cutter is ready for operation, conduct the following.

The operator's manual and safety signs affixed on the unit contain important instructions on the safe and proper use of the equipment. Maintain these important safety features on the implement in good condition to ensure the information is available to the operator at all times.

- Ensure the manual canister is secured to the equipment with the operator's manual inside.
- Ensure all safety signs are in place and legible. Replace missing, damaged, and illegible decals.

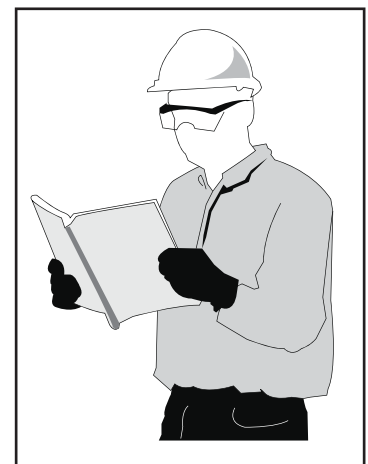

OPERATION SECTION

Cutter Pre-Operation Inspection/Service continued

- Perform scheduled lubrication as detailed in the maintenance section.
- Ensure all decals are in place and legible.
- Ensure the driveline is securely attached to tractor. Make sure the driveline yoke locking collar is securely seated in the grooves of the PTO shaft by pushing and pulling the yoke several times.
- Ensure deflectors and/or chainguards are in position and not damaged. Replace worn, broken, and missing pieces.
- Inspect all bolts and screws and tighten to the recommended torque.
- Ensure the driveline integral shield is in good condition and rotates freely.
- Ensure the driveline slip clutch (if equipped) is properly adjusted.
- Inspect the gearbox oil level. A low oil level is a warning sign that the gearbox may be cracked or its seal is damaged and needs replacement.
- Ensure the gearbox vent is in place and free from clogs.
- Inspect blades and blade bolts for looseness and excessive wear. Make sure the cutter is securely blocked up before crawling beneath. Replace damaged, worn and missing blades as complete sets to maintain rotary balance during operation.
- Ensure carrier hub nut is tightened with the cotter pin inserted and spread.



All Safety Shields, Guards and Safety devices should be used and maintained in good working condition. All safety devices should be inspected carefully at least daily for missing or broken components. Missing, broken, or worn items must be replaced at once to reduce the possibility of injury or death from thrown objects, entanglement, or blade contact.

OPERATION SECTION

Rotary Cutter PRE-OPERATION Inspection

Cutter ID# _____ Make _____
 Date: _____ Shift _____

Before conducting the inspection, make sure the tractor engine is off, all rotation has stopped and the tractor is in park with the parking brake engaged. Make sure the cutter is resting on the ground or securely blocked up.

Item	Condition at Start of Shift	Specific Comments if not O.K.
The Operator's Manual is in the canister on the cutter		
All safety decals are in place and legible		
The hitch connection bolts & pins are tight		
The cutter deck is clear of cut grass and debris		
Chain guards/deflectors are in place & in good condition		
Driveline/gearbox shields are in good condition		
Driveline telescoping members & U-joints are lubricated		
Driveline yokes are securely attached to PTO & cutter		
Gearbox mounting bolts are tight		
Gearbox oil is at the proper level		
Blade carrier retaining nut is tight		
Blades are not chipped, cracked or bent		
Blade bolts are tight		
Wheel lug nuts are tight		

Operator's Signature: _____

DO NOT OPERATE an UNSAFE TRACTOR or Cutter

OPERATION SECTION

Tractor PRE-OPERATION Inspection

Cutter ID# _____ Make _____

Date: _____ Shift _____

Before conducting the inspection, make sure the tractor engine is off, all rotation has stopped and the tractor is in park with the parking brake engaged. Make sure the cutter is resting on the ground or securely blocked up.

Item	Condition at Start of Shift	Specific Comments if not O.K.
The flashing lights function properly		
The SMV Sign is clean and visible		
The tires are in good condition with proper pressure		
The wheel lug bolts are tight		
The tractor brakes are in good condition		
The steering linkage is in good condition		
There are no visible oil leaks		
The hydraulic controls function properly		
The ROPS or ROBS Cab is in good condition		
The seatbelt is in place and in good condition		
The 3-point hitch is in good condition		
The drawbar pins are securely in place		
The PTO master shield is in place		
The engine oil level is full		
The brake fluid level is full		
The power steering fluid level is full		
The fuel level is adequate		
The engine coolant fluid level is full		
The radiator is free of debris		
The air filter is in good condition		

Operator's Signature: _____

DO NOT OPERATE an UNSAFE TRACTOR or Cutter

OPERATION SECTION

DRIVING THE TRACTOR AND IMPLEMENT

Safe tractor transport requires the operator possess a thorough knowledge of the model being operated and precautions to take while driving with an attached implement. Ensure the tractor has the capacity to handle the weight of the implement and the tractor operating controls are set for safe transport. To ensure safety while driving the tractor with an attached implement, review the following.



DANGER

The Implement and Tractor to pivot violently resulting in loss of steering control, serious injury, or even death.



DANGER

Never allow the Implement to contact obstacles.



WARNING

Transport only at speeds where you can maintain control of the equipment. Serious accidents and injuries can result from operating this equipment at high speeds. Understand the Tractor and Implement and how it handles before transporting on streets and highways. Make sure the Tractor steering and brakes are in good condition and operate properly.

Before transporting the Tractor and Implement, determine the proper transport speeds for you and the equipment. Make sure you abide by the following rules:

Test the tractor at a slow speed and increase the speed slowly. Apply the Brakes smoothly to determine the stopping characteristics of the Tractor and Implement. As you increase the speed of the Tractor the stopping distance increases.

Be aware of the operating conditions. Do not operate the Tractor with weak or faulty brakes

or worn tires. When operating down a hill or on wet or rain slick roads, the braking distance increases: use extreme care and reduce your speed. When operating in traffic always use the Tractor's flashing warning lights and reduce your speed. Be aware of traffic around you and watch out for the other guy.



OPERATION SECTION

Inclines and ditches should be approached along a line which is at an angle as shown. This type of path will reduce the possibility of over-collapse of the driveline and resulting damage. If the gradient is so steep that such an approach increases the possibility of a tractor roll-over, select an alternate crossing path.

When operating the tractor and cutter across slopes and inclines, through ditches, and other uneven terrain conditions, it is important to maintain sufficient deck to ground clearance. Blade contact with the ground may cause soil, rocks and other debris to be thrown out from under the cutter resulting in possible injury and/or property damage. Ground contact also produces a severe shock load on the cutter drive and to the cutter blades resulting in possible damage and premature wear.

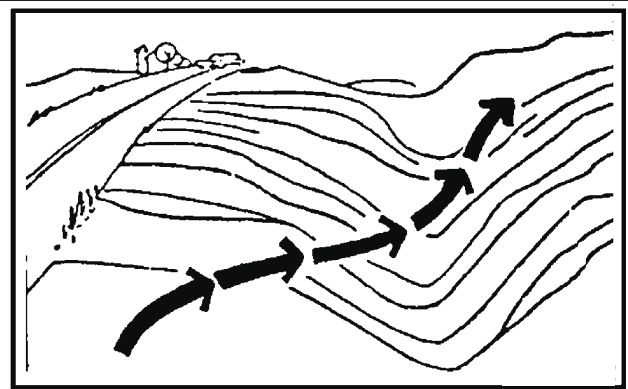

CORRECT: Approach ditch at an angle

OPERATING THE TRACTOR AND IMPLEMENT

THE OPERATOR MUST COMPLETELY UNDERSTAND HOW TO OPERATE THE TRACTOR AND IMPLEMENT AND ALL CONTROLS BEFORE ATTEMPTING TO OPERATE. The operator must read and understand the Safety and Operation Sections of the implement and tractor operator's manuals. These manuals must be read and explained to any operator who cannot read. Never allow someone to operate the implement and tractor without complete operating instructions.

Before starting any operation, the operator must become familiar with the area to be worked in and any obstacles and hazards contained within to ensure safety to the operator, bystanders, and equipment. Special attention should be paid to foreign debris, rough terrain, steep slopes, and passersby and animals in the area.

WARNING

Extreme care should be taken when operating near loose objects such as gravel, rocks, wire, and other debris. Inspect the area before mowing. Foreign objects should be removed from the site to prevent machine damage and/or bodily injury or even death. Any objects that cannot be removed must be clearly marked and carefully avoided by the operator. Stop mowing immediately if blades strike a foreign object. Repair all damage and make certain rotor or blade carrier is balanced before resuming mowing.



OPERATION SECTION

Rotary Cutters are capable under adverse conditions of throwing objects for great distances (300 feet or more) and causing serious injury or death. Follow safety messages carefully.



STOP MOWING IF PASSERSBY ARE WITHIN 100 YARDS UNLESS:

- Front and Rear Deflectors, Chain Guards, or Bands are installed and in good, workable condition;
- Passersby are outside the existing thrown-object zone;
- All areas have been thoroughly inspected and all foreign material such as rocks, cans, glass, and general debris has been removed.

NOTE: Where there are grass and weeds high enough to hide debris that could be struck by the blades, the area should be: inspected and large debris removed, mowed at an intermediate height, inspected, closely with any remaining debris being removed, and mowed again at desired final height. (This will also reduce power required to mow, reduce wear and tear on the Cutter drivetrain, spread cut material better, eliminate streaking, and make the final cut more uniform).

Engaging the Power Take Off (PTO)

Before engaging the PTO, make certain that the area is clear of bystanders and passersby. The implement must be completely lowered and the deck positioned at a safe operating height. NEVER engage the PTO with the implement in the raised position.

Set the tractor engine speed at approximately 1,000 RPM before engaging the PTO. Shift the PTO control to the on position, and slowly increase the engine speed until the PTO is operating at the rated speed. If you hear unusual noises or see or feel abnormal vibrations, disengage the PTO immediately. Inspect the implement to determine the cause of the noise or vibration and repair the abnormality.

! WARNING

Do not let the Blades turn when the Cutter Deck is raised for any reason, including clearance or for turning. Raising the Cutter deck exposes the Cutting Blades which creates a potentially serious hazard and could cause serious injury or even death from objects thrown from the Blades.

! WARNING

Do not put hands or feet under cutter decks. Blade Contact can result in serious injury or even death. Stay away until all motion has stopped and the decks are securely blocked up.



OPERATION SECTION

Many varied objects, such as wire, cable, rope, or chains, can become entangled in the operating parts of the cutter head. These items could then swing outside the housing at greater velocities than the blades. Such a situation is extremely hazardous and could result in serious injury or even death. Inspect the cutting area for such objects before mowing. Remove any like object from the site. Never allow the cutting blades to contact such items.

Foreign Debris Hazards

Before mowing, inspect the area to make sure there are no foreign objects that the cutter blades could hit or become entangled with. Remove all foreign objects and debris. If objects are too big to remove, mark them clearly and be sure to prevent the cutter blades from contacting them.

If you hit a solid object or foreign debris, stop the cutter and tractor at once. Immediately idle the engine speed and disengage the PTO. Wait for all cutter rotating motion to stop, then raise the cutter and move the tractor and implement off the object. Inspect the area and remove, or mark the location of the debris. Inspect the condition of the cutter and make any needed repairs immediately. Make sure the blades are not damaged and the carrier is balanced before resuming operation.

Always wear your seat belt securely fastened and only operate the tractor and cutter with the ROPS in the raised position. If the tractor or cutter hits a tree stump, rock, or bump, a sudden movement could throw you off of the seat and under the tractor and/or cutter. The seat belt is your best protection from falling off the tractor and the ROPS provides protection from being crushed during a tractor roll-over.

Bystanders/Passersby Precautions

If a bystander comes within 300 feet of the tractor while the cutter is being operated, stop the tractor at once, idle the engine and disengage the PTO. Do not engage the PTO again until all bystanders are well past the 300 foot distance.

OPERATION SECTION

PTO RPM and Ground Speed

Ground speed for mowing will depend upon the height, type, and density of vegetation to be cut. Recommended speed for efficient cutter performance is between 2 and 5 mph. Operate the cutter at its full rated PTO speed to maintain blade speed for a clean cut. Refer to the tractor operator's manual or the tractor instrument panel for the engine speed and gear to provide the required PTO and desired ground speed. Make sure that the cutter is operating at its full rated speed before entering the vegetation to be cut. If it becomes necessary to temporarily regulate engine speed, increase or decrease the throttle gradually.

Ground speed is achieved by transmission gear selection and not by the engine operating speed. The operator may be required to experiment with several gear range combinations to determine the best gear and range which provides the most ideal performance from the cutter and most efficient tractor operation. As the severity of cutting conditions increase, the ground speed should be decreased by selecting a lower gear to maintain the proper operating PTO speed.



Do not exceed the rated PTO speed for the Implement. Excessive PTO speeds can cause implement driveline or blade failures resulting in serious injury or death.



Mow at the speed that you can safely operate and control the tractor and cutter. Safe mowing speed depends on terrain condition and grass type, density, and height of cut. Normal ground speed range is from 2 to 5 mph. Use slow mowing speeds when operating on or near steep slopes, ditches, drop-offs, overhead obstructions, power lines, or when debris and foreign objects are to be avoided.

Operating the Cutter

Only operate the cutter from the tractor operator's seat with the seatbelt securely fastened. The tractor must be equipped with a ROPS in the raised position or a ROPS cab.

The cutter is designed to cut vegetation up to 2" in diameter. Sharp blades will produce a cleaner cut and require less power. Travel at a speed that allows the cutter sufficient time to cut through the vegetation and maintain the PTO operating speed to prevent overloading the cutter and tractor. Choose a driving pattern that provides the maximum pass length and minimizes turning.

Under certain conditions, tractor tires may roll some grasses down preventing them from being cut at the same height as the surrounding area. When this occurs, reduce the tractor ground speed while maintaining the operating speed of the cutter. A slower ground speed will permit grasses to at least partially rebound and be cut. Taking a partial cut and/or reversing the direction of travel may also help produce a cleaner cut.

Avoid mowing in the reverse direction when possible. In situations where the cutter must be backed to access areas to be cut, make sure there are no persons or other foreign debris behind the cutter before mowing in reverse. When mowing in reverse, operate the tractor and cutter at a reduced ground speed to ensure tractor and cutter control is maintained.

OPERATION SECTION

WARNING

Do not mow with two machines in the same area except with Cab tractors with the windows closed.

WARNING

Mow only in conditions where you have clear visibility in daylight or with adequate artificial lighting. Never mow in darkness or foggy conditions where you cannot clearly see at least 100 yards in front and to the sides of the tractor and cutter. Make sure that you can clearly see and identify passersby, steep slopes, ditches, drop-offs, overhead obstructions, power lines, debris and foreign objects. If you are unable to clearly see these type of items discontinue mowing.

WARNING

Avoid mowing in reverse direction when possible. Check to make sure there are no persons behind the cutter and use extreme care when mowing in reverse. Mow only at a slow ground speed where you can safely operate and control the tractor and cutter. Never mow an area that you have not inspected and removed debris or foreign material.

WARNING

Follow these guidelines to reduce the risk of equipment and grass fires while operating, servicing, and repairing the Cutter and Tractor:



- Equip the Tractor with a fire extinguisher in an accessible location.
- Do Not operate the Cutter on a Tractor with an underframe exhaust.
- Do Not smoke or have an open flame near the Cutter and Tractor.
- Do Not drive into burning debris or freshly burnt areas.
- Ensure slip clutches are properly adjusted to prevent excessive slippage and plate heating. (When Applicable)
- Never allow clippings or debris to collect near drivelines, slip clutches, and gearboxes. Periodically shut down the Tractor and Cutter and clean clippings and collected debris from the cutter deck.

OPERATION SECTION

CUTTER STORAGE

Properly preparing and storing the cutter at the end of the season is critical to maintaining its appearance and to help ensure years of dependable service. The following are suggested storage procedures:

- Thoroughly clean all debris off the cutter to prevent damage from rotting grass and standing water.
- Lubricate all cutter grease points and fill gearbox oil levels as detailed in the maintenance section.
- Tighten all bolts and pins to the recommended torque.
- Check the cutter for worn and damaged parts. Perform repairs and make replacements immediately so that the cutter will be ready for use at the start of the next season.
- Store the cutter in a clean, dry place with the cutter housing resting securely on blocks or at ground level.
- Keep the driveline yoke from sitting in water, dirt and other contaminants.
- Use spray touch-up where necessary to prevent rust and maintain the appearance of the cutter.



DANGER

Never allow children to play on or around Tractor or Implement. Children can slip or fall off the Equipment and be injured or killed. Children can cause the Implement to shift or fall crushing themselves or others.

TRANSPORTING THE TRACTOR AND IMPLEMENT

Inherent dangers of operating the tractor and implement and the possibility of accidents are not left behind when you finish working in an area. Therefore, the operator must employ good judgement and safe operation practices when transporting the tractor and implement between locations. By using good judgement and following safe transport procedures, the possibility of accidents while moving between locations can be substantially minimized.



DANGER

Never allow children or other persons to ride on the Tractor or Implement. Falling off can result in serious injury or death.

OPERATION SECTION

Transporting on Public Roadways

Extreme caution should be used when transporting the tractor and cutter on public roadways. The tractor must be equipped with all required safety warning features including a SMV emblem and flashing warning lights to alert drivers of the tractor's presence. Remember that roadways are primarily designed for automotive drivers and most drivers will not be looking out for you, therefore, you must look out for them. Check your side view mirrors frequently and remember that vehicles will approach quickly because of the tractor's slower speed.

WARNING

Only tow the Implement behind a properly sized and equipped Tractor which exceeds the weight of the Implement by at least 20%. DO NOT tow the Implement behind a truck or other type of vehicle.

DANGER

Never allow children or other persons to ride on the Tractor or Implement. Falling off can result in serious injury or death.

WARNING

Make certain that the "Slow Moving Vehicle" (SMV) sign is installed in such a way as to be clearly visible and legible. When transporting the Equipment use the Tractor flashing warning lights and follow all local traffic regulations.

The SMV (Slow-Moving Vehicle) emblem is universal symbol used to alert drivers of the presence of equipment traveling on roadways at a slow speed. SMV signs are a triangular bright orange with reflective red trim for both easy day and night visibility. Make sure the SMV sign is clean and visible from the rear of the unit before transporting the tractor and implement on a public roadway. Replace the SMV emblem if faded, damaged, or no longer reflective.



OPERATION SECTION

TROUBLE	POSSIBLE CAUSE	POSSIBLE REMEDY
<i>Excessive Vibration</i>	1. Check gearbox bolts.	Tighten if loose.
	2. Check for loose nuts on blade holder and blades.	Tighten if loose.
	3. Check for bent output shaft. If shaft is bent, cutter will have excessive vibration.	Replace shaft if bent.
	4. Check to see if blades are free swinging.	Free blades so they swing.
	5. Check for even wear on each blade tip. Change both blades at the same time.	Weigh blades. Weight should be within 1 oz. Always replace both blades.
	6. Blade broken.	Replace the set of blades.
	7. Blade carrier bent.	Replace carrier.
	8. Blade hub not properly seated on shaft (it is loose).	Tighten shaft nut to 350 torque ft. lbs.
	9. New blade or bolts matched with worn blade or bolts.	Replace blades or bolts in sets.
<i>Gearbox Overheating</i>	1. Low on lubricant.	Fill to overflow plug.
	2. Improper type lubricant.	Replace with proper lubricant.
	3. Excessive trash buildup around gearbox.	Remove trash.
	4. Bearing or gears set up improperly.	Consult your dealer.
<i>Uneven Cutting</i>	1. Blades not sharp.	Sharpen or replace blades.
	2. Tractor PTO speed turning less than 540 RPM.	Use correct PTO speed and check for correct gearbox ratio. See specifications.
	3. Cutter not level.	See Cutting Height Adjustment.
	4. Tractor tires mashing down grass.	Reverse direction of cutting and drive with one tractor tire out of cutter overlap area. Conditions too wet to cut.
	5. Ground speed too fast.	Reduce ground speed by shifting to a lower gear.
	6. Blades locked back.	Free blades.
	7. Blades riding up due to blade bolt wear or loose bolts.	Replace all blade bolt assemblies.

OPERATION SECTION

TROUBLE	POSSIBLE CAUSE	POSSIBLE REMEDY
<i>Streaking Conditions</i>	1. Conditions too wet for cutting. Blades unable to cut that part of grass pressed down by tractor tires.	Allow grass to dry before cutting. Slow ground speed of tractor but keep engine running at full PTO 540 RPM. Cutting lower may help.
	2. Dull blades.	Sharpen or replace blades.
<i>Blade Bolts</i>	1. Bolts not tightened.	Tighten bolts to 350 ft. lbs.
<i>Gearbox Noisy</i>		Return to authorized Modern dealer service department.
<i>Gearbox Leaking</i>	1. Damaged oil seal.	Replace seal.
	2. Bent shaft.	Replace oil seal and shaft.
	3. Shaft rough in oil seal area.	Replace or repair shaft.
	4. Oil seal installed wrong.	Replace seal.
	5. Sand in hole in gearbox housing.	Replace gearbox housing.
	6. Gasket damaged.	Replace gasket.
	7. Bolts loose.	Tighten bolts.
<i>Shear Pin Shears Excessively</i>	1. Tractor PTO not being run at 540 RPM.	Run at 540 RPM.
	2. Heavy material.	Reduce ground speed. Raise cutting height.
	3. Not using proper pin	Replace only with recommended shear pin.

This page intentionally left blank.

MAINTENANCE SECTION

Before operating your Rotary Cutter, make sure it is properly lubricated and thoroughly inspected. Only a minimum of time and effort is required to regularly lubricate and maintain this machine to provide long life and trouble free operation.

WARNING: Always disengage the PTO before raising the Rotary Cutter for transporting or making adjustments.

Lubrication

Do not let excess grease collect on or around parts, particularly when operating in sandy areas. The chart gives the frequency of lubrication in hours, based on normal operating conditions. Severe or unusual conditions may require more frequent lubrication.

Use an SAE multipurpose, lithium-type grease for all locations shown. Be sure to clean the fitting thoroughly before using grease gun. Daily lubrication of the driveline slip joint is necessary. Failure to maintain proper lubrication will result in damage to U-joints, gearbox, and/or driveshaft.

DRIVELINE LUBRICATION

Grease Fittings are located on the Cross Assembly of each U-Joint and on the telescoping tubes. Grease the U-Joint after each 8 hours of use. Do not force grease through the Needle Cup Assemblies. Grease the telescoping tubes after every 8 hours use. Some PTO-to-Hitch connections may necessitate cutting a hole in the shields to be able to align the Grease Fitting holes for lubrication. Lubricate the shield bearings every 40 hours.

! CAUTION

Make certain that the Driveline Integral Shields are free to telescope and rotate around the Driveline without binding.

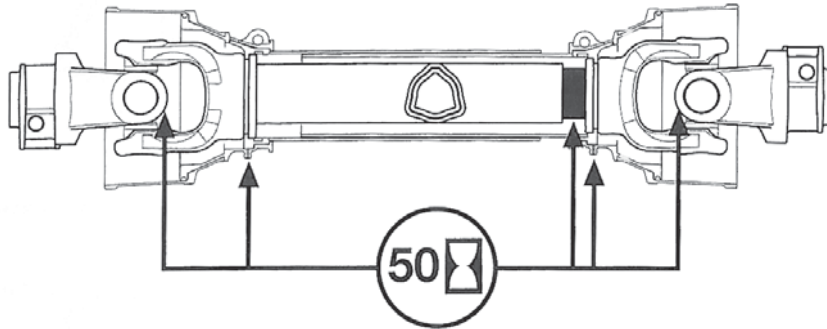

LIFT TYPE DRIVELINE & PULL JACKSHAFT SHIELDS

To remove the main inner driveline shield, Remove the locking screws. Align the bearing tabs with the cone pockets. Remove the half-guard and remove the bearing ring.

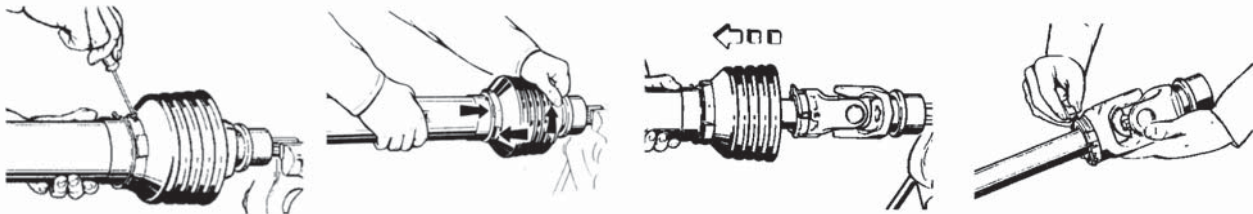

Inspect the driveline shield for worn areas or cracks. If the shield has any dents or cracks, replace the Shield. While the Shields are off, examine the Driveline for signs of abnormal wear, bent or twisted shafts, or cracks in the shafts or tubes. Check to see that the Drivelines telescope easily. If the Drivelines do not telescope properly or show signs of abnormal wear, the shaft should be repaired or replaced.

MAINTENANCE SECTION

SLIP CLUTCHES

A slip clutch is incorporated in the PTO driveline. It is designed to slip, absorb the shock load, and protect the driveline. Clutch torque setting is **NOT** factory set. If clutch slips excessively, check friction discs for excessive wear. To adjust clutch, first check length of springs assembled on clutch. Length should be $1 \frac{1}{8}$ (28.5 mm). If not, adjust length of bolt to obtain proper spring length. If additional adjustment is required, tighten each bolt $\frac{1}{4}$ turn. **NOTE: DO NOT** tighten spring bolts over $\frac{1}{4}$ turn at any adjustment. Excessive tightening can cause clutch to become frozen and not slip which could cause damage to the tractor PTO, drivelines, or gearbox. Plates should be checked weekly for oil or grease, wear, and moisture which could cause corrosion on the drive plates.

Avoid over heating of clutches caused by too long frequent slipping of the clutch since this can damage the friction plates and clutch parts. When checking slip clutch for overheating, do not touch with hand. Clutch could be extremely hot and cause severe burn.

REGULAR CLUTCH MAINTENANCE

It is important that the clutches slip when an obstacle or load heavier than the clutch setting is encountered. Before using the cutter, after not using for any period of time, use the following procedure to make sure the clutch will slip and give the overload protection required.

1. Loosen spring nut until the spring is free, and then retighten approximately one turn.
2. Attach machine to tractor, set engine at approximately half throttle and quickly engage PTO. The procedure will break clutch facings loose and allow the proper torque to be maintained.
3. Return the nuts and bolts to their original position of $1 \frac{1}{8}$ " compressed spring length for 540 RPM.

Note: if machine sits outside longer than 10 days and is exposed to rain and humid air, the clutches should be removed from machine and store in dry area. Clutch facing will soak up moisture and cause the metal plates to rust badly. When this occur, the break-away torque increases greatly and damage to gearbox, driveline, or tractor PTO can occur.

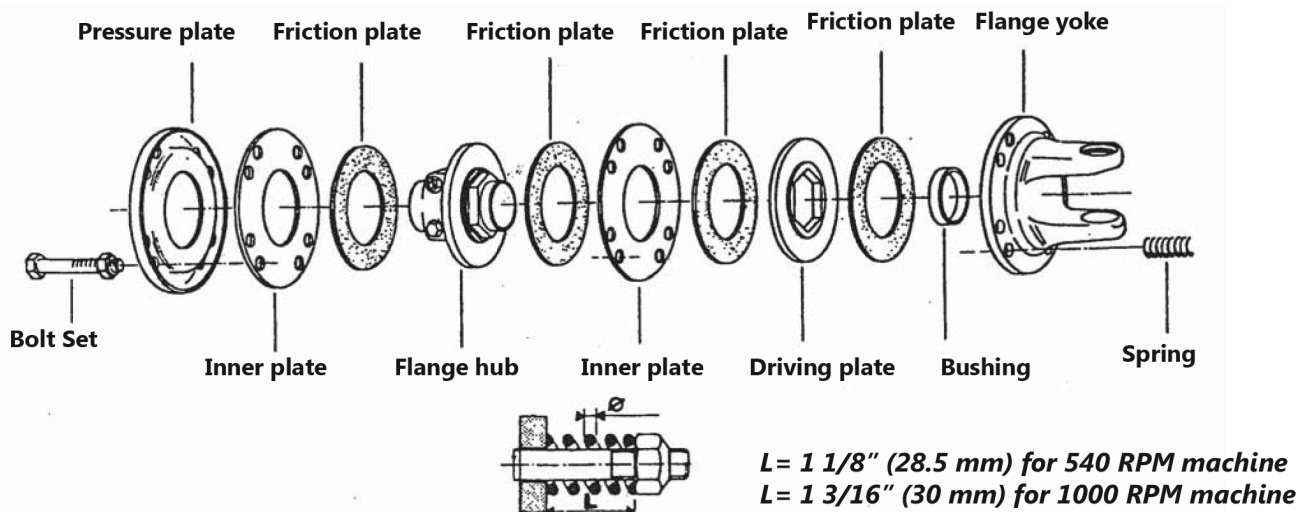

MAINTENANCE SECTION

To assemble the main inner driveline shield, grease the yoke groove and inner profile tube. Attach the bearing ring in groove with recesses facing profile tube. FIGURE Mnt-0027. Slide on the half shield. Turn the cone until it engages correctly. Install locking screws.

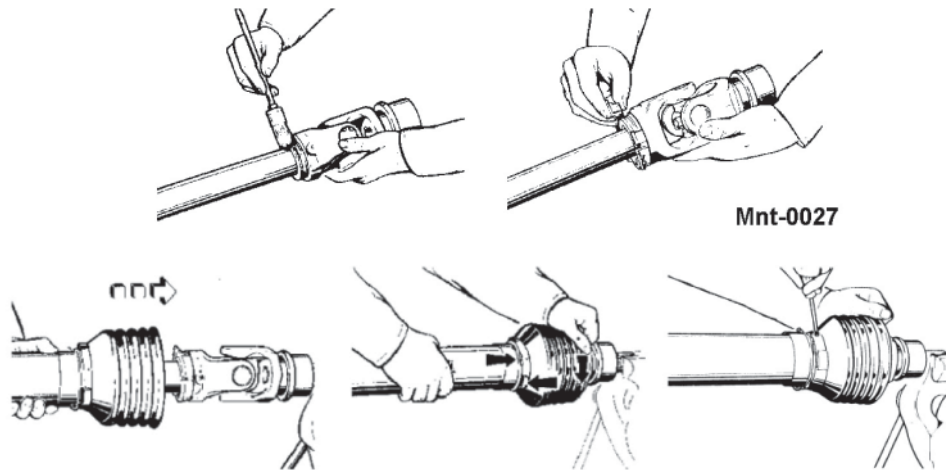

CV TYPE DRIVELINE

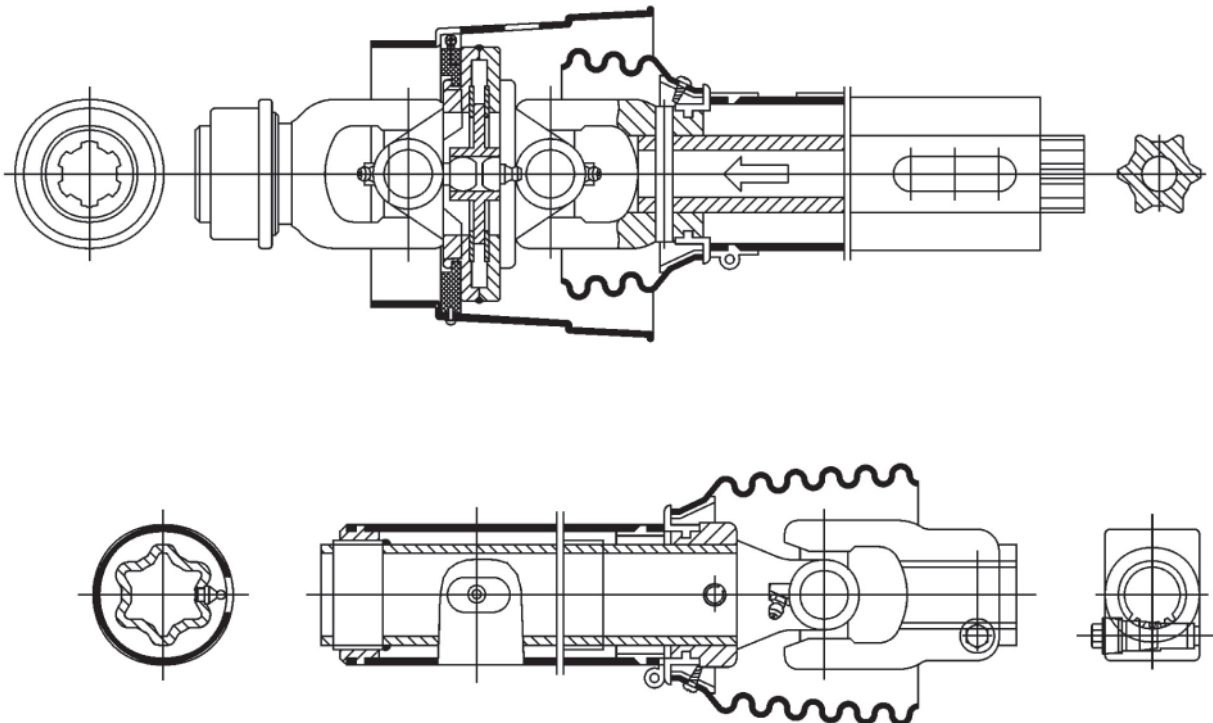

MAINTENANCE SECTION

BLADE SERVICING

Inspect blade before each use to determine that they are properly installed and in good condition. Replace any blade that is bent, excessively nicked, worn or has any other damage. Small nicks can be ground out when sharpening. Using only original equipment blades on this cutter. They are made of special heat-treated alloy steel. Substitute blades may not meet specification and may dangerous.

Blade Sharpening

Always sharpen both blades at same time to maintain balance. Follow original sharpening pattern. Always sharpen blades by grinding. DO NOT heat and pound out edge. Do not sharpen blade to a razor edge, but leave a 1/16" blunt edge. Do not sharpen back side of blade.

IMPORTANT: When sharpening blades, grind each blade the same amount to maintain balance. The difference in blade weights should not exceed 1 ounce. Unbalanced blades will cause excessive vibration which can damage gear box bearings. Vibration may also cause structural cracks in cutter housing.

Never work under equipment support by a hydraulic device because it may drop if the control is actuated (even with the engine stopped) or in the event of hose failure, etc. Always use a secure support for equipment which must be serviced while in the raised position.

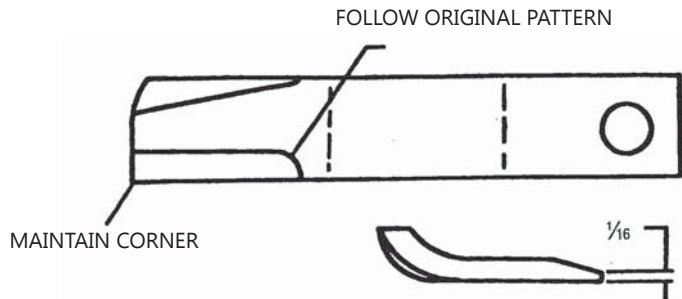

MAINTENANCE SECTION

BLADE REMOVAL

To removed blades for sharpening or replacement, remove the cover plate on deck of cutter near each gearbox. Remove locknut from blade bolt. Inspect lock nut after removal and replace if threads or nylon insert are damaged. Always replace nut when replacing bolt. When installing blades, be sure to check blade bolt pivot diameter for wear. Replace bolt if worn more than 1/4 at any point. Install blade bolts with worn side of bolt away from the center of the blade carrier. Tighten lock nut to 300 ft. lbs.



Avoid personal injury. Blade and/or bade carrier removal should be done only with the tractor engine shut off, key removed, in neutral, parking brake on, PTO disengaged, and the cutter blocked in the raised position. Avoid personal injury. Do not work under cutter without support blocks to keep frame from falling.

BLADE CARRIER REMOVAL

Remove cotter pin and loosen slotted nut on gear box shaft. Loosen but do not remove the nut until the blade carrier is loosened. Use a suitable two-jaw gear puller to pull carrier tapered gear box shaft. If gear puller is not available use long bar inserted through blade bolt access hole with end against rotor bar. Strike opposite end of bar with sledge hammer. Rotate blade carrier 180 degrees and repeat process.

HARDWARE

Check nuts, bolts, and other miscellaneous hardware regularly. Loose hardware is easily lost, cause increased wear on parts, and increase the chance of breakdown. Loose hardware creates potential hazards which could result in personal injury to the operator, support personnel and bystanders. Use the "Torque Chart" below when tightening bolted connections.

RECOMMENDED TORQUE IN FT-LBS (NM) COARSE AND FINE THREADS

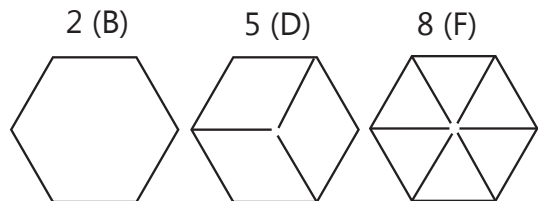

BOLT DIAMETER	PLAIN HEAD	THREE DASHES	SIX DASHES
1/4	not used	10 (14)	14 (19)
5/16	not used	20(27)	30(41)
3/8	not used	35(47)	50(68)
7/16	35(47)	55(75)	80(108)
1/2	55(75)	85(115)	120(163)
9/16	75(102)	130(176)	175(237)
5/8	105(142)	170(230)	240(325)
3/4	185(251)	300(407)	425(576)
7/8	160(217)	445(603)	685(929)
1	250(339)	670(906)	1030(1396)
1 1/8	330(447)	910(1234)	1460(1979)
1 1/4	480(651)	1250(1695)	2060(2793)

GEARBOX MAINTENANCE

GEARBOX

The oil level should be checked and maintained at a "full" level. To fill, remove the oil fill plug (1), the overflow plug (2), add oil until oil overflows. *Figure 1.*

Note: 90wt. or 90 EPO oil is recommended.

Note: Make sure cutter is level when checking oil in the gearbox.

Note: Failure to remove 1/4" overflow plug may cause overfilling. Overfilling of gearbox will cause pressure to build up and cause oil seals to leak.

TAILWHEEL:

Grease fitting on hub of wheel. *Figure 2.* Grease after every 4 hours. Also, a grease fitting is provided on the tailwheel boom at caster pivot point. *Figure 3.* Grease after every 4 hours use to provide maximum trouble free service.

IMPORTANT: Fill gearbox with EP-90 Type lubricant.

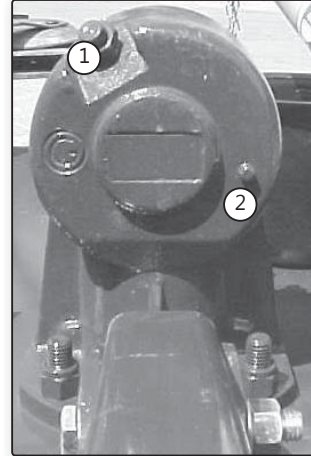

Figure 1



Figure 2

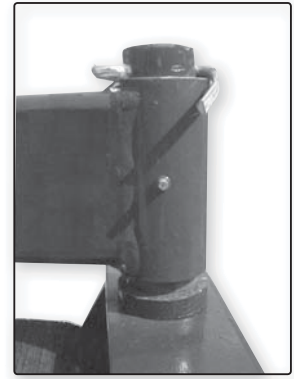

Figure 3

CUTTER LUBRICATION POINTS

Tailwheel boom
bushing every
8 hrs.

Check fluid in
gearbox daily.

Tailwheel hub
every 8 hrs.

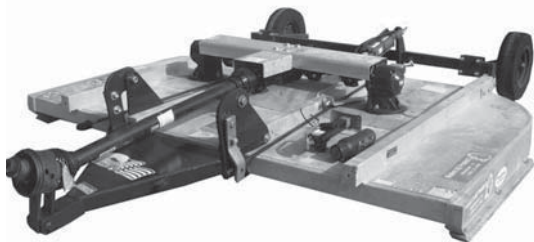

Driveline Lubrication

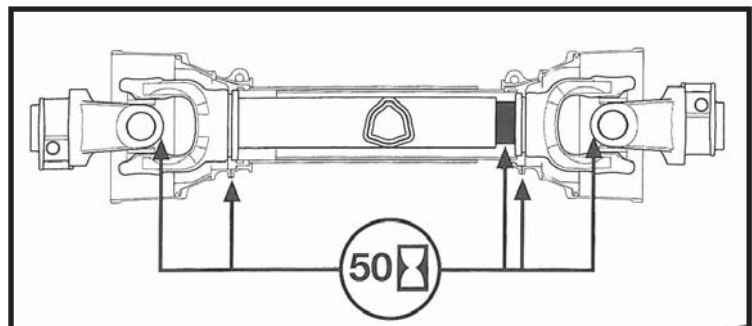

ASSEMBLY/PARTS SECTION

8' FT PREDATOR PARTS SECTION

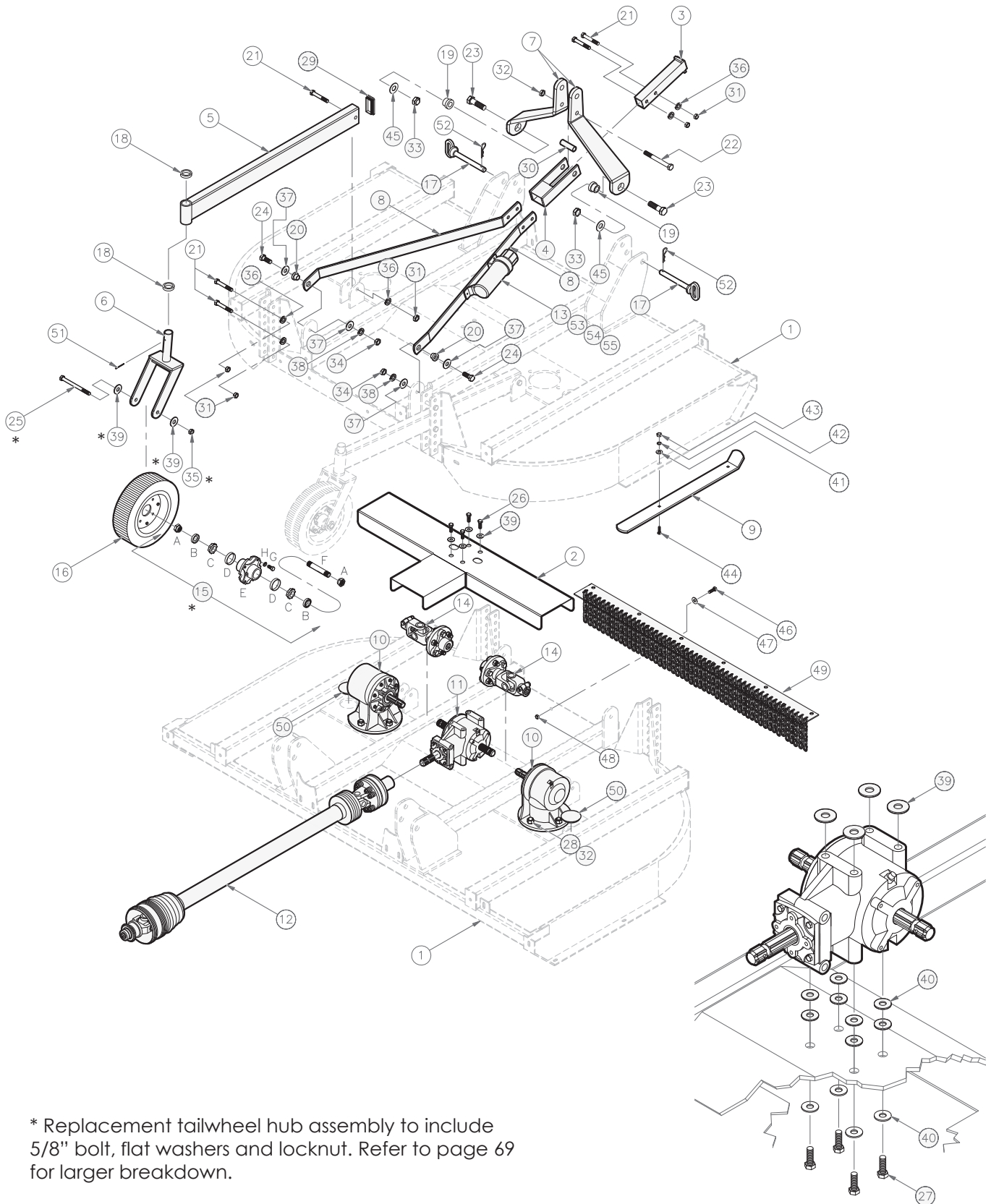

8' FT PREDATOR PARTS SECTION

8' Predator Quick Attach Main Assembly

Item	Part Number	Description	Qty
1.....	401-QA8PDECKWIP.....	8' Predator Quick Attach Body.....	1
2.....	115-070025.....	8'/10' Driveline Cover Shield.....	1
3.....	115-8140.....	Inner Slide Tube Weldment.....	1
4.....	115-8145.....	Outer Slide Weldment.....	1
5.....	116-1030.....	Tail Wheel Boom Weldment.....	2
6.....	116-6487-01.....	Tail Wheel Yoke.....	2
7.....	610-1020.....	A-Frame, Quick Attach Cat II.....	2
8.....	101-1024QA.....	Stiff Arm.....	2
9.....	108-6068.....	Skid, Bolt-On (2 Hole).....	2
10.....	401-0170-01.....	Gearbox, 1-3/8" 15Z 1:1.93.....	2
11.....	900-070101-02.....	Transfer Gearbox.....	1
12.....	401-0312-03.....	PTO, 1-3/8"-6 x 1-3/8"-6 FF2.....	1
13.....	412-9099.....	Manual Holder.....	1
14.....	401-0322.....	Shock Coupler.....	2
*15.....	900-1444A.....	Tail Wheel Hub Assembly, 5/8".....	2
15A.....	401-0065.....	Turndown Nut, 1".....	2
15B.....	322-2703.....	Tail Wheel Seal.....	2
15C.....	324-3227.....	Bearing Cone, L44634.....	2
15D.....	324-3226.....	Bearing Race, L44610.....	2
15E.....	325-2510.....	Tail Wheel Hub W/ Cups.....	1
15F.....	105-1159.....	5-3/8" Threaded Tail Wheel Sleeve.....	1
15G.....	512-0650.....	Bolt, 1/2"-20 x 1".....	4
15H.....	412-0072.....	Lock Washer, 1/2".....	4
16.....	103-209.....	Laminated Tail Wheel, 4x8.....	2
17.....	155-2008.....	Hitch Pin, Cat II.....	2
18.....	101-7552.....	Spacer, Tail Wheel Yoke.....	4
19.....	150-6308.....	Large Step Down Bushing.....	2
20.....	150-6307.....	Small Step Down Bushing.....	2
21.....	412-11320.....	Bolt, 5/8" x 4".....	8
22.....	412-2133.....	Bolt, 3/4" x 6-1/2".....	1
23.....	412-0048-01.....	Bolt, 1" x 3-1/2".....	2
24.....	412-2755.....	Bolt, 3/4" x 2-1/2".....	2
*25.....	412-5283.....	Bolt, 5/8" x 7-1/2" GR5.....	2
26.....	412-4965.....	Bolt, 5/8" x 1-1/2" GR5.....	4
27.....	412-4965-01.....	Bolt, 5/8" x 1-1/2" GR8.....	4
28.....	115-8146.....	Gearbox Bolt Strap, 3/4".....	4
29.....	116-1657.....	Cap Plug, Tail Wheel Boom.....	2
30.....	412-5400-01.....	Pivot Bushing, 3-1/2".....	1
31.....	412-0059.....	Hex Nut, 5/8".....	8
32.....	401-0060.....	Nylock Nut, 3/4".....	9
32A.....	412-37314.....	Nylock Nut, 3/4".....	8
33.....	412-0068.....	Nylock Nut, 1".....	2
34.....	412-0061.....	Hex Nut, 3/4".....	2
*35.....	412-5284.....	Nylock Nut, 5/8".....	2
36.....	412-0073.....	Lock Washer, 5/8".....	8
37.....	412-0077.....	Flat Washer, 3/4".....	4
38.....	412-0074.....	Lock Washer, 3/4".....	4
*39.....	412-0076.....	Flat Washer, 5/8".....	12
40.....	412-0076-01.....	Flat Washer SAE, 5/8".....	12
41.....	412-0075.....	Flat Washer, 3/8".....	4
42.....	412-0071.....	Lock Washer, 3/8".....	4
43.....	412-0657.....	Hex Nut, 3/8".....	4
44.....	412-03229.....	Plow Bolt, 3/8" x 1-1/2".....	4
45.....	412-7975.....	Flat Washer, 1".....	2
46.....	412-0042-02.....	Bolt, 1/2"X1-1/2".....	8
47.....	412-0072-01.....	Flat Washer, 1/2".....	8
48.....	412-0058.....	Hex Nut, 1/2".....	8
49.....	101-3593.....	Rear Chain Guard.....	1
50.....	116-1656.....	Mower Deck Plug.....	2
51.....	412-0081.....	Cotter Pin.....	2
52.....	154-5.....	Hitch Pin Clip.....	2
53.....	412-0009.....	Bolt, 1/4"x 1-1/4".....	2
54.....	412-0007.....	Lock Washer, 1/4".....	2
55.....	412-0082.....	Hex Nut, 1/4".....	2

8' FT PREDATOR PARTS SECTION

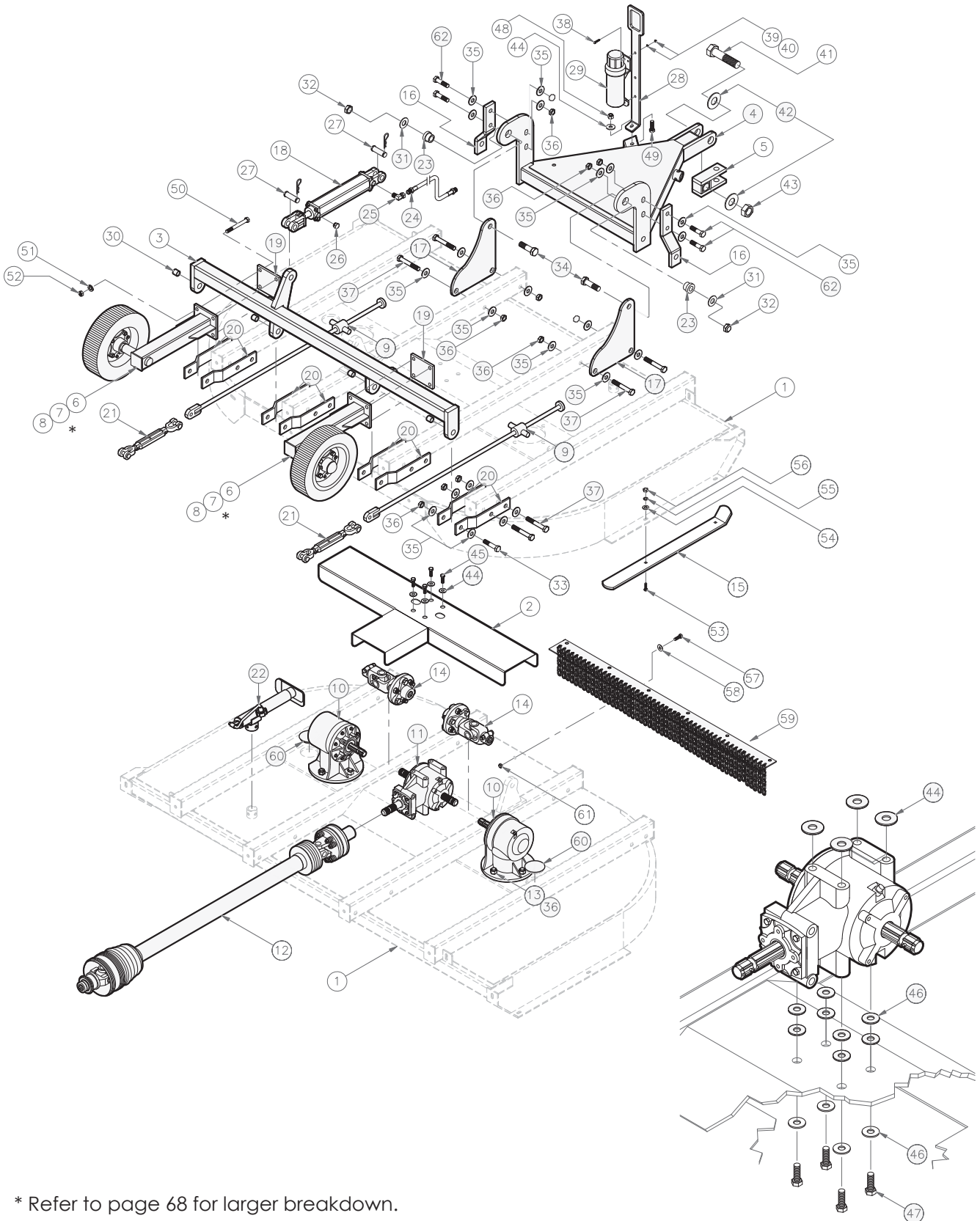

8' FT PREDATOR PARTS SECTION

8' Predator Drag Main Assembly

Item	Part Number	Description	Qty
1	401-8PDECKWIP	8' Predator Drag Body	1
2	115-070025	8'/10' Driveline Cover Shield	1
3	115-070073-8	8' Axle Weldment	1
4	115-070047	8'/10' Drag Tongue	1
5	115-070055	8'/10' Tongue Clevis	1
6	115-070057	8'/10' Single Spindle	2
	115-070058	8'/10' Double Spindle (Option Only)	2
*7	415-0050-00	Wheel Hub Package, 719	2
8	103-211	Tail Wheel, 6 x 9	2
9	8-LEVROD	Leveling Rod	2
10	401-0170-01	Gearbox, 1-3/8" 15Z 1:1.93	2
11	900-070101-02	Transfer Gearbox	1
12	401-0325-04	PTO Complete w/ Slip Clutch	1
13	115-8146	Gear Box Bolt Strap, 3/4"	4
14	401-0322	Shock Coupler	2
15	108-6068	Skid, Bolt On (2-Hole)	2
16	105-070065	Trunnion Bracket	2
17	105-070067	8'/10' Mount Plate	2
18	263-3288	Hydraulic Cylinder, 3x8	1
19	105-39032	Spindle Mount Plate	2
20	105-070072	8' Axle Mounting Bracket	8
21	900-070059-J	Turnbuckle	2
22	457-1609	Jack, Topwind #5000 LB	1
23	150-6308	Large, Step Down Bushing	2
24	415-0140	Hydraulic Hose, 3/8" x 140"	1
25	800-0203	Elbow, 8MP X 8FP X 90°	1
26	97-2	Breather Plug	1
27	261-700	Cylinder Pin	2
28	610-1608	Hydraulic Line Holder	1
29	412-9099	Manual Holder	1
30	412-5402	Bushing, Axle Arm 1"	4
31	412-7975	Flat Washer, 1"	2
32	412-0068	Nylock Nut, 1-8	2
33	412-15365	Bolt, 3/4" x 3" GR8	4
34	412-0048-01	Bolt, 1-8 x 3-1/2"	2
35	412-0077	Flat Washer, 3/4"	40
36	412-0060	Nylock Nut, 3/4"	28
36A	412-37314	Nylock Nut, 3/4"	8
37	412-2131	Bolt, 3/4" x 5" GR5	12
38	412-0009	Bolt, 1/4" x 1-1/4"	2
39	412-0007	Lock Washer, 1/4"	2
40	412-0082	Hex Nut, 1/4"	2
41	412-0603	Bolt, 1-1/2"-6 x 6-1/2"	1
42	638-24	Flat Washer, 1-1/2"	2
43	412-0604	Top Lock Nut, 1-1/2"	1
44	412-0076	Flat Washer, 5/8"	9
45	412-4965	Bolt, 5/8" x 1-1/2" GR5	4
46	412-0076-01	Flat Washer SAE, 5/8"	12
47	412-4965-01	Bolt, 5/8" x 1-1/2" GR8	4
48	412-5284	Nylock Nut, 5/8"-11	1
49	412-0023-02	Tap Bolt, 5/8" x 2" GR5	1
50	412-0028-01	Bolt, 5/8" x 5-1/2"	8
51	412-0073	Lock Washer, 5/8"	8
52	412-0059	Hex Nut, 5/8"	8
53	412-03229	Plow Bolt, 3/8" x 1-1/2"	4
54	412-0075	Flat Washer, 3/8"	4
55	412-0071	Lock Washer, 3/8"	4
56	412-0657	Hex Nut, 3/8"	4
57	412-0042-02	Bolt, 1/2" x 1-1/2"	8
58	412-0072-01	Flat Washer, 1/2"	8
59	101-3593	Rear Chain Guard	1
60	116-1656	Mower Deck Plug	2
61	412-0058	Hex Nut, 1/2"	8
62	412-15365	Bolt, 3/4" x 3" GR8	4

8' FT PREDATOR PARTS SECTION

CLOCKWISE ROTATION

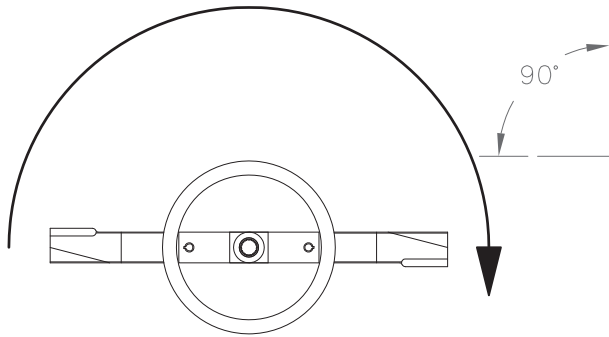

COUNTER CLOCKWISE ROTATION

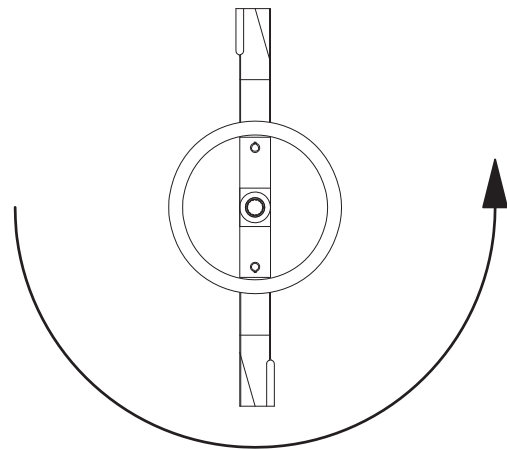

NOTE: CUTTER BLADES MUST BE INDEXED 90° TO PREVENT COLLISION

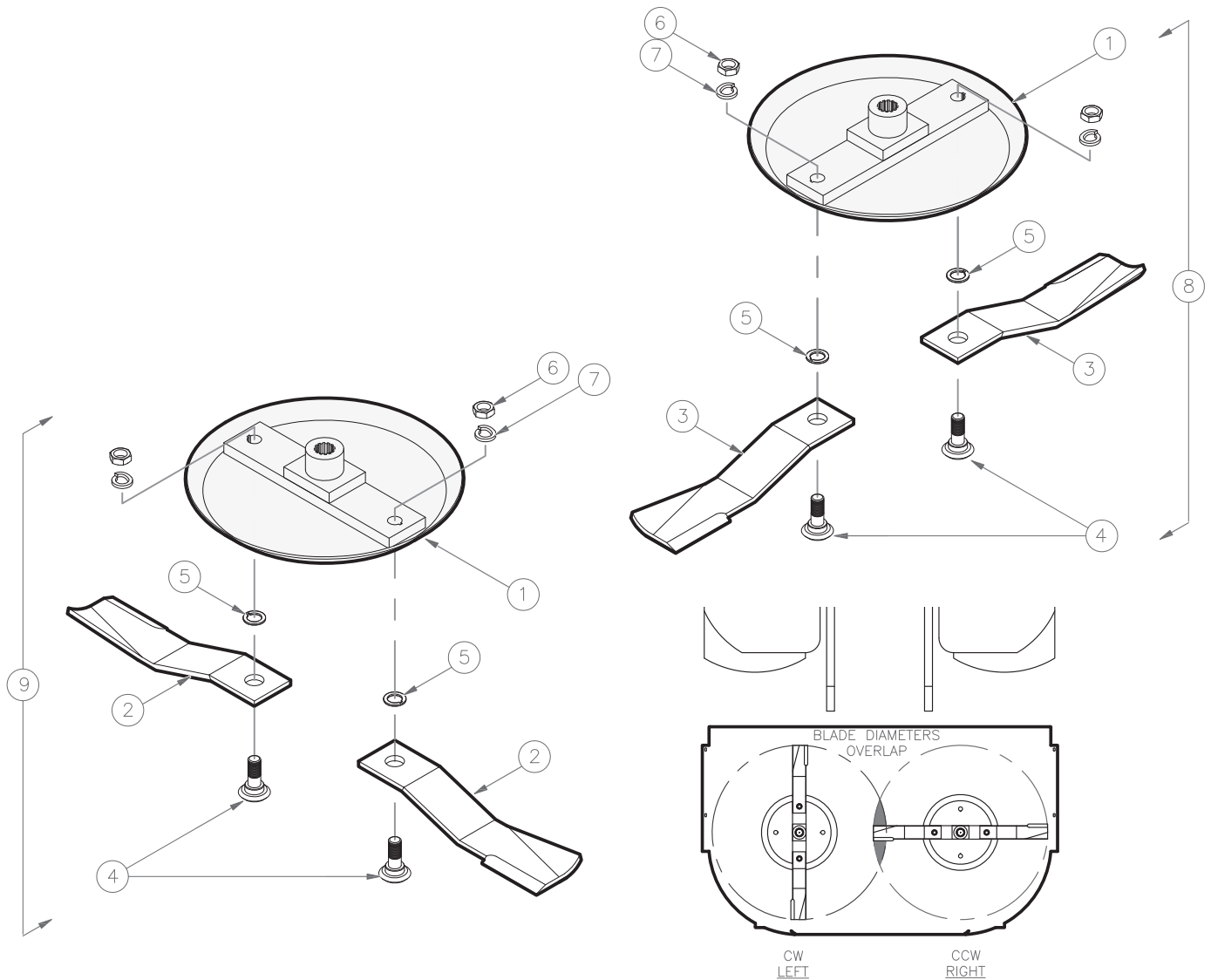

8' FT PREDATOR PARTS SECTION

8' Blade Carrier Assembly

Item	Part Number	Description	Qty
1.....	101-1003.....	Blade Carrier.....	1
2.....	125-1372.....	Blade, CW Rotation 8590.....	2
3.....	125-1371.....	Blade, CCW Rotation 8589.....	2
4.....	412-0057-01.....	Blade Bolt.....	4
5.....	830-1018NH.....	Washer W/ Keyway.....	4
6.....	125-925.....	Jam Nut, 1-1/8" Gr 8.....	4
7.....	900-8771.....	Lock Washer, 1-1/8".....	4
.....	412-8043-01.....	Blade Bolt Assembly 1-1/8 x 3-1/2 (Includes 4,6,7)	4

8' FT PREDATOR PARTS SECTION

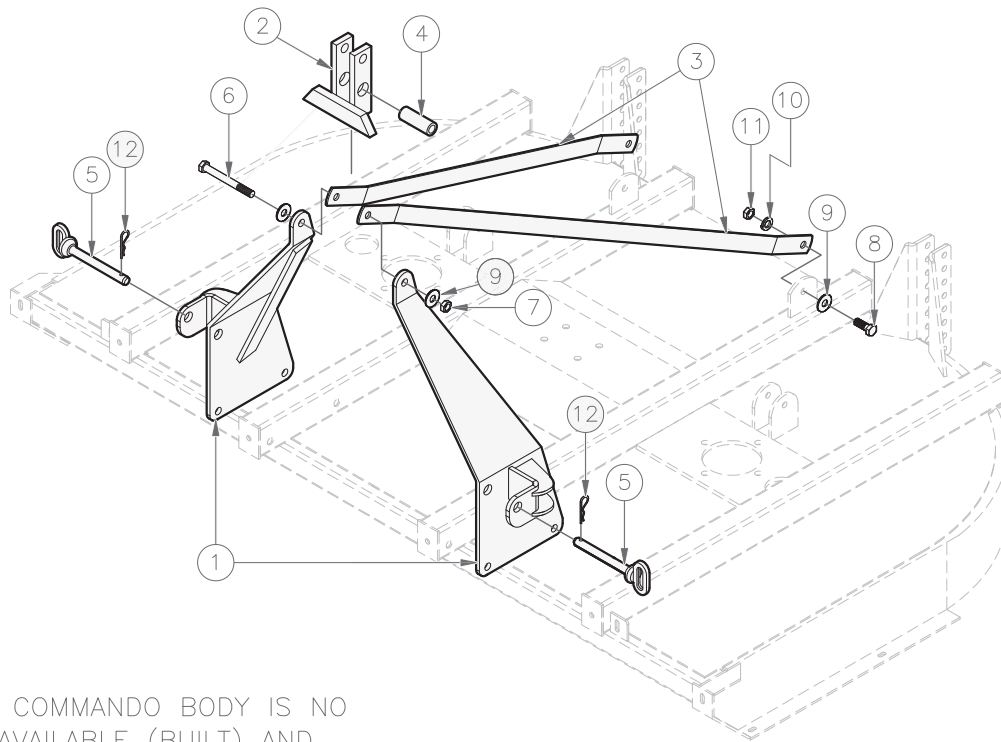

NOTE: 8' COMMANDO BODY IS NO LONGER AVAILABLE (BUILT) AND A-FRAMES & SWIVELS WILL ONLY BE MADE BY SPECIAL REQUEST.

8' FT PREDATOR PARTS SECTION

8' Commado Lift Type Assembly

Item	Part Number	Description	Qty
*1	101-1023-L	A-Frame, Cat II, LH	1
	101-1023-R	A-Frame, Cat II, RH	1
*2	101-1002	Swivel Hitch Weldment	1
3	116-1025	Stiff Arm	2
4	101-1022	Flex Hitch Bushing	1
5	155-2008	Hitch Pin, Cat II	2
6	412-2133	Bolt, 3/4" x 6-1/2"	1
7	401-0060	Nylock Nut, 3/4"	1
8	412-2755	Bolt, 3/4" x 2-1/2"	2
9	412-0077	Flat Washer, 3/4"	4
10	412-0074	Lock Washer, 3/4"	2
11	412-0061	Hex Nut, 3/4"	2
12	154-5	Hitch Pin Clip, 5/32" x 2-15/16"	2

(*) See note when referring to this part.

8' FT PREDATOR PARTS SECTION

401-0170-01 * Gearbox

ITEM	PART NO.	QUANTITY	DESCRIPTION
1	501-0770	1	HOUSING
2	501-0233	1	OUTPUT CAP
3	501-0915	1	INPUT CAP
4	501-0265	1	INPUT GEAR, 29T
5	501-0260	1	OUTPUT PINION, 15T
6	501-0262	1	INPUT SHAFT
7	501-0235	2	BEARING CONE
8	501-0240	2	BEARING CONE
9	501-0239	2	BEARING CUP
10	501-0274	1	BEARING CUP
11	501-0277	1	BEARING CUP
12	501-0232	1	OUTPUT SEAL
13	322-1213	1	INPUT SEAL
14	501-0243	VAR	INPUT GASKET
17	501-0249	VAR	OUTPUT GASKET
20	501-0236	1	SPACER
21	501-0287	1	SPACER
22	900-8951	1	COTTERPIN
23	501-0253	8	CAPSCREW, 3/8" X 1 1/4"
24	501-0251	4	CAPSCREW, 1/2" x 1 1/2"
25	501-0266	1	FLANGE NUT
26	412-0071	8	LOCKWASHER, 3/8"
27	412-0072	4	LOCKWASHER, 1/2"
28	501-0254	1	PIPE PLUG, 1/8"
29	501-0757	1	PLUG, PRESSURE RELIEF
31	501-0245	1	RETAINER RING
32	401-5160	1	HUB-FOR REFERENCE ONLY

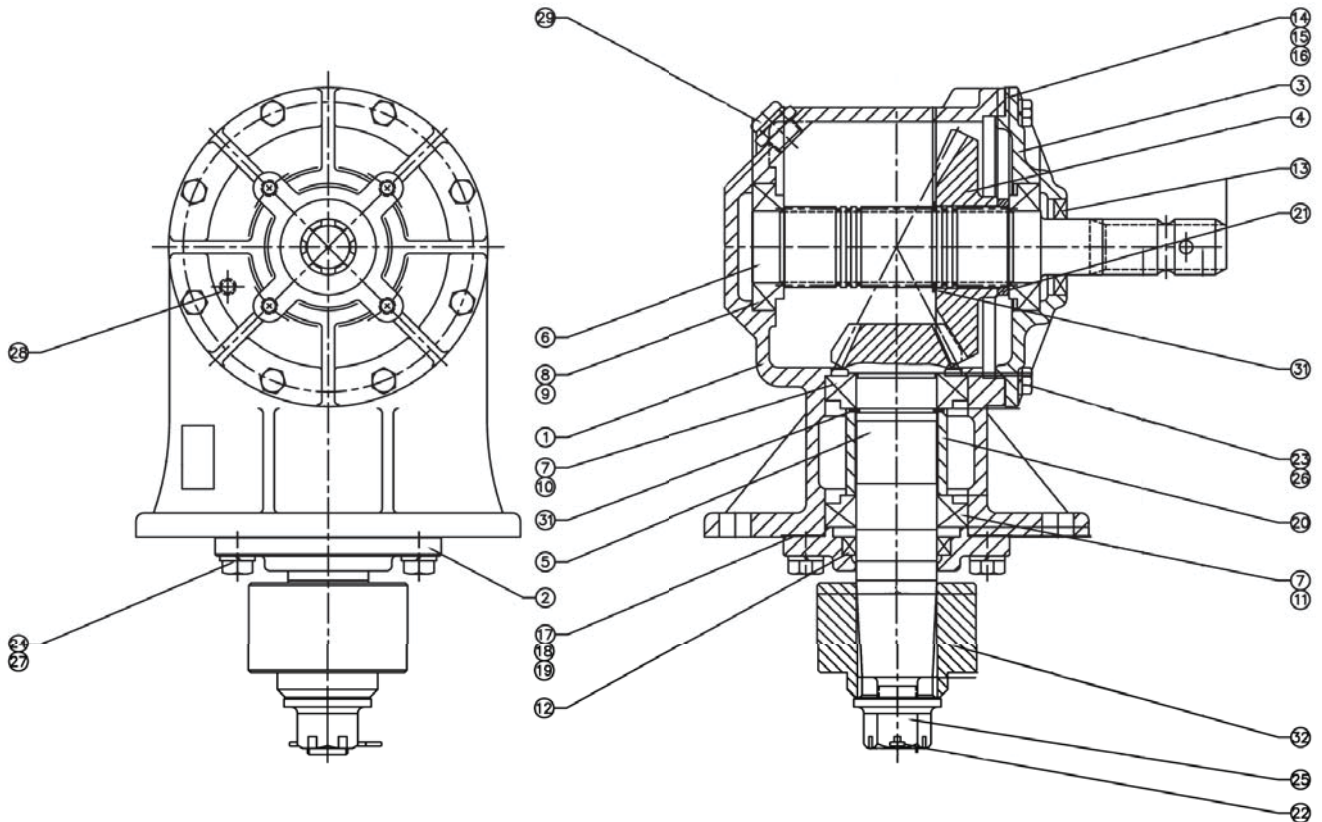

8' FT PREDATOR PARTS SECTION

900-070101-02 * Gearbox

ITEM	PART NO.	QUANTITY	DESCRIPTION
1	501-0600-01	1	HOUSING
2	501-0915	1	COVER
3	501-0606	1	COVER
4	501-0608	1	GEAR, 17T
5	501-0607	1	GEAR, 14T
6	501-0603	1	THROUGH SHAFT
7	501-0601-01	1	INPUT SHAFT
8	501-0235	2	BEARING CONE
9	501-0240	2	BEARING CONE
10	501-0239	2	BEARING CUP
11	501-0274	1	BEARING CUP
12	501-0277	1	BEARING CUP
13	501-0232	1	SEAL
14	322-1213	2	SEAL
15	501-0243	VAR	GASKET
18	501-0249	VAR	GASKET
21	501-0602	1	SPACER
22	501-0253	8	CAPSCREW, 3/8" X 1 1/4"
23	501-0251	4	CAPSCREW, 1/2" X 1 1/2"
24	501-0252	8	LOCKWASHER, 3/8"
25	501-0250	4	LOCKWASHER, 1/2"
26	501-0255	1	PLUG, 1/2"
27	501-0254	1	PLUG, 1/8"
28	501-0757	1	PLUG PRESSURE RELIEF
30	501-0245	1	RETAINER RING

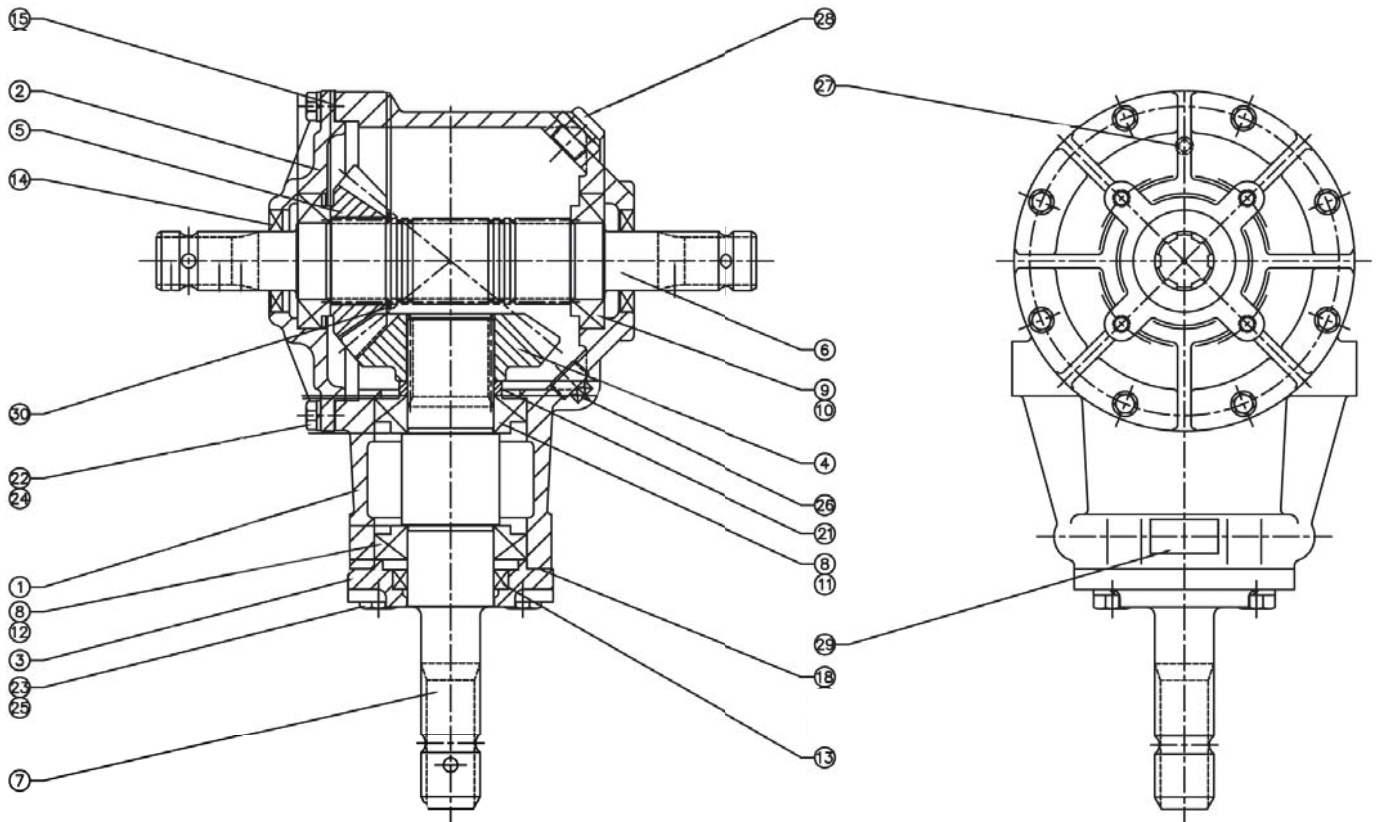

8' FT PREDATOR PARTS SECTION

401-0325-04

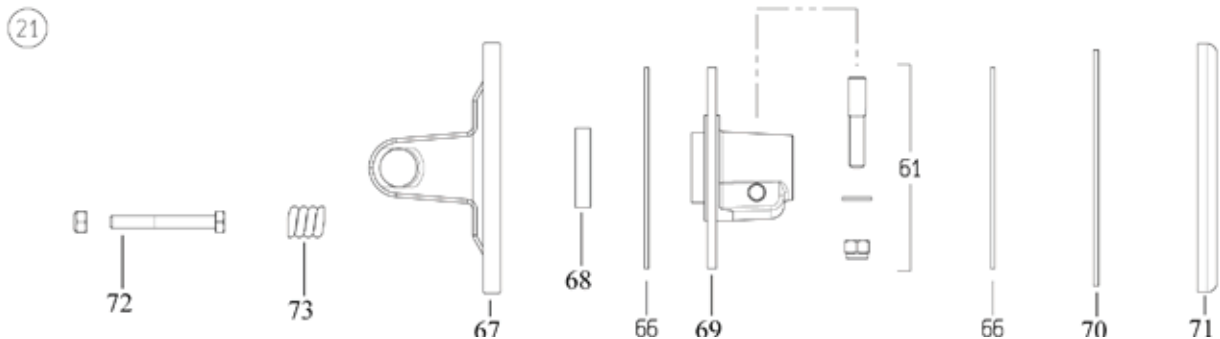
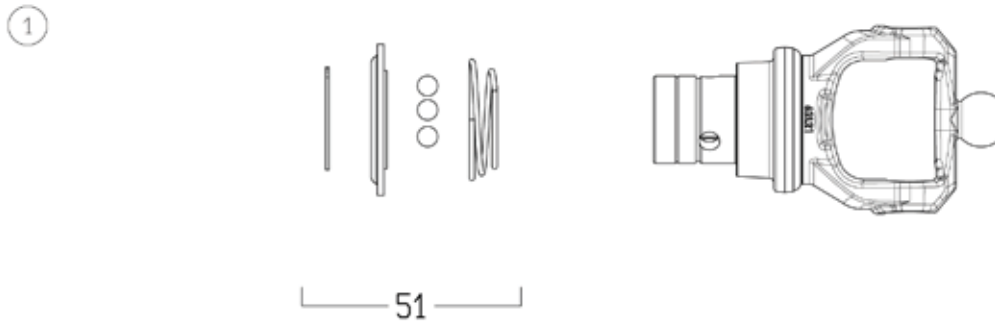
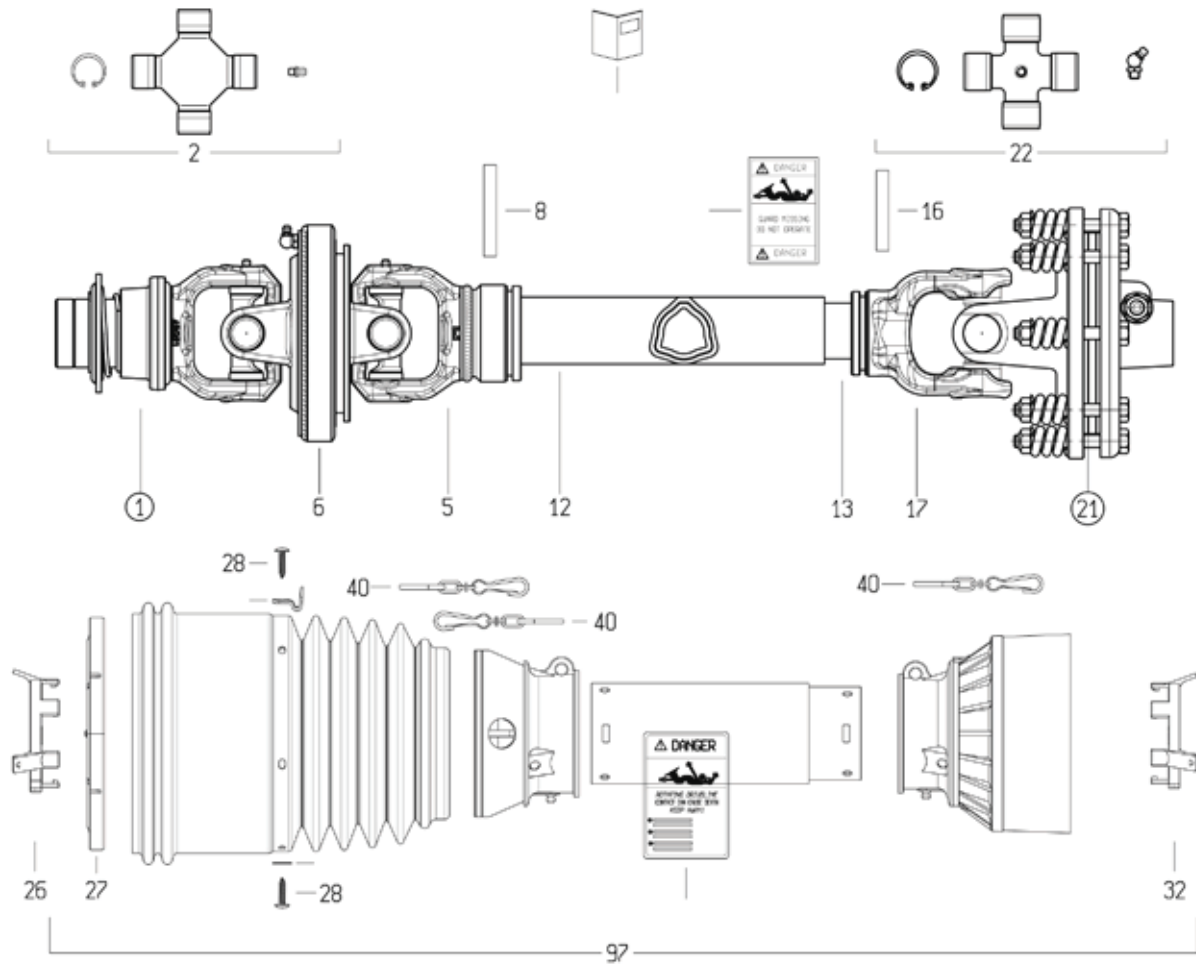

8' FT PREDATOR PARTS SECTION

401-0325-04 * 8' PULL TYPE PTO SHAFT AND CLUTCH ASSEMBLY

ITEM	PART NO.	QUANTITY	DESCRIPTION
1	501-0533-01	1	YOKE S6 1R6 1-3/8Z6 80[CV (R07)
2	501-0534-01	2	CROSS KIT S6 SFT 80° EL 27X100
5	501-0536-01	1	OUTER TUBE YOKE 1R6
6	501-0535-01	1	CENTRAL BODY SFT CV S6
8	343-1505	1	FLEXIBLE ROLL PIN #67 OUTER 10X65MM
12	501-0537	1	OUTER TUBE
13	501-0538	1	INNER TUBE
16	343-1504	1	FLEXIBLE ROLL PIN #6/7 INNER 10X65MM
17	343-1306	1	YOKE #6 INNER TUBE
21	501-0483-01	1	SLIP CLUTCH
22	343-1212	1	CROSS KIT #6 30.2X91.5 ZERK IN BODY
26	343-1979	1	SHIELD SUPPORT #6-7 OUTER 6G502
27	501-0542-01	1	SHIELD SUPPORT SFT EL CV80 S6 CV50 S6-S8
32	343-1980	1	SHEILD SUPPORT #6-7 INNER 6G602
40	501-0526	3	COMPLETE CHAIN
51	501-1102	1	BALL COLLAR KIT
51A	501-1102-02	1	BALL COLLAR KIT AUTOLOCK
61	501-0484	1	TAPER PIN W/NUT
66	501-0488-01	2	LINING 162X85X3.2 FD3/33 - FT-FV42/44
67	501-0486-01	1	FLANGE YOKE
68	501-0487	1	COLLAR/BUSHING
69	501-0489-01	1	CLUTCH HUB
70	501-0490-01	1	INNER PLATE, 4MM
71	501-0491-01	1	PRESSURE PLATE
72	501-0492	8	BOLT & NUT
73	125-815	8	TENSION SPRING
97	501-0574-01	1	COMPLETE DRIVELINE SHEILD

8' FT PREDATOR PARTS SECTION

401-0312-03

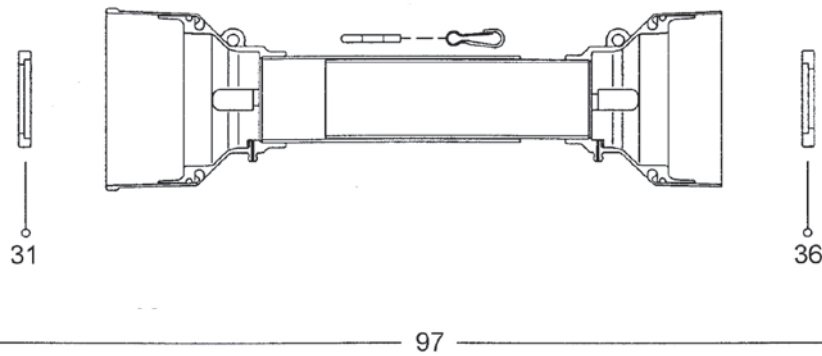
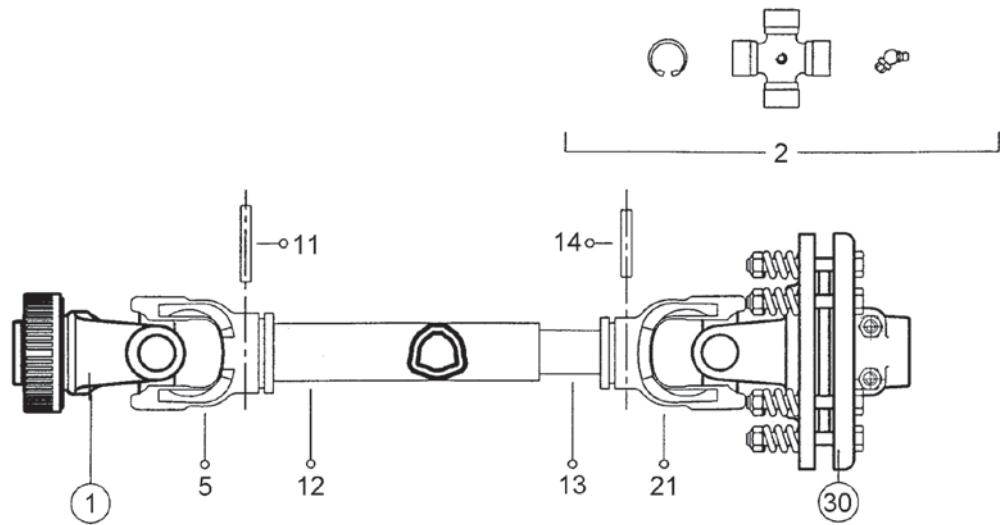

①



③①

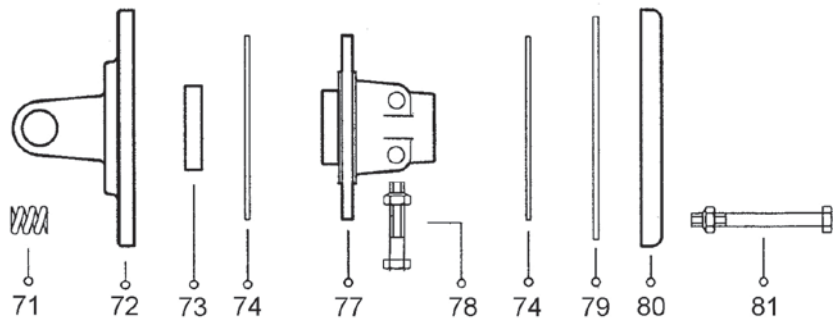

8' FT PREDATOR PARTS SECTION

401-0312-03 * 8' LIFT TYPE PTO SHAFT AND CLUTCH ASSEMBLY

Item	Part Number	Description	Qty
1.....	501-1101.....	Yoke #6/s7 1-3/8" z6 ball (r07)	1
2.....	343-1212.....	Cross journal Assy	2
5.....	343-1706.....	Yoke #6 outer tube.....	1
11.....	343-1505.....	Flexible roll pin #6/7 outer 10x75mm	1
12.....	501-1103	Drive tube #6 outer l=715mm.....	1
13.....	501-1104.....	Cardan drive tube #6 inner l=715.....	1
14.....	343-1504.....	Flexible roll pin #6/7 inner 10x65mm	1
21.....	343-1306.....	Yoke #6 inner tube	1
30.....	501-0483-01	Clutch 1 3/8- 6z ff2	1
53.....	501-1102.....	Ball collar kit 1-3/8"z6 & z21	1
71.....	125-815.....	Spring.....	8
72.....	501-0486-01	Flange yoke #6 ft22	1
73.....	501-0487.....	Bushing ff /ff2/ff3/ff4/clutch	1
74.....	501-0488-01	Friction disc	2
77.....	501-0489-01	Hub 1-3/8"z6	1
78.....	501-0484.....	Pin	1
79.....	501-0490-01	Inner plate.....	1
80.....	501-0491-01	Pressure plate	1
81.....	501-0492.....	Screw and nut	8
97.....	083E06160SC*	Safety guard.....	1

*CUT TO LENGTH

8' FT PREDATOR PARTS SECTION

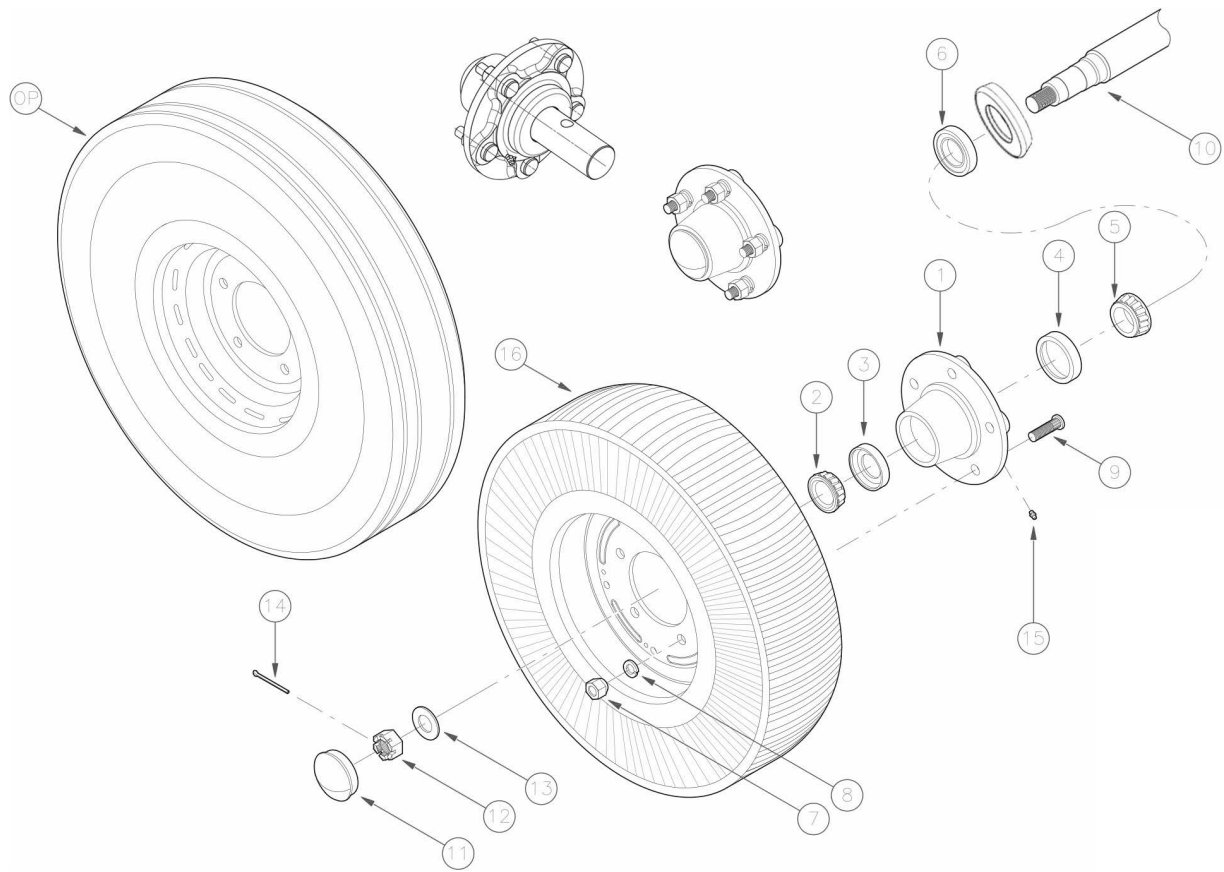

Wheel Hub Assembly - Bolt On Spindles

Item	Part Number	Description	Qty
1.....	415-0050-01	Hub w/races, studs & zerk	1
2.....	501-0219	Bearing cone (outside)	1
3.....	501-0218	Bearing cup (outside)	1
4.....	900-602406	Bearing cup (inside)	1
5.....	900-602416	Bearing cone (inside)	1
6.....	415-0050-03	Seal	1
7.....	325-2122	Nut	5
8.....	412-0072	Washer, 1/2"	5
9.....	325-2112	Stud	5
10.....	512-0004-1	Single Spindle	1
11.....	415-0050-05	Dust Cap	1
12.....	415-0050-02	Slotted Nut	1
13.....	415-0050-04	Washer	1
14.....	900-8686	Cotter Pin	1
15.....	423-1121	Grease Zerk	1
16.....	103-226	Laminated Tire, 6 x 10 x 25	1
17.....	415-0050-09	Dirt Protector Cap (threaded)	1
18.....	415-0050-00A	Hub complete less spindle	1
19.....	512-0004A	Hub complete with spindle	1
OP.....	401-8813	Tire & Wheel 26.5 x 8.0 x 14	1

8' FT PREDATOR PARTS SECTION

900-1444A TAILWHEEL HUB ASSEMBLY

Item	Part Number	Description	Qty
1.....	412-5283.....	Bolt, 5/8" x 7-1/2" GR5	1
2.....	412-0076.....	Flat Washer, 5/8"	2
3.....	401-0065.....	Turndown Nut, 1"	2
4.....	322-2703.....	Tail Wheel Seal.....	2
5.....	324-3227.....	Bearing Cone, L44634.....	2
6.....	324-3226.....	Bearing Race, L44610	2
7.....	325-2510.....	Tail Wheel Hub W/ Cups.....	1
8.....	105-1159.....	5-3/8" Threaded Tail Wheel Sleeve	1
9.....	512-0650.....	Bolt, 1/2"-20 x 1"	4
10.....	412-0072.....	Lock Washer, 1/2"	4
11.....	412-5284.....	Nylock Nut, 5/8"	1

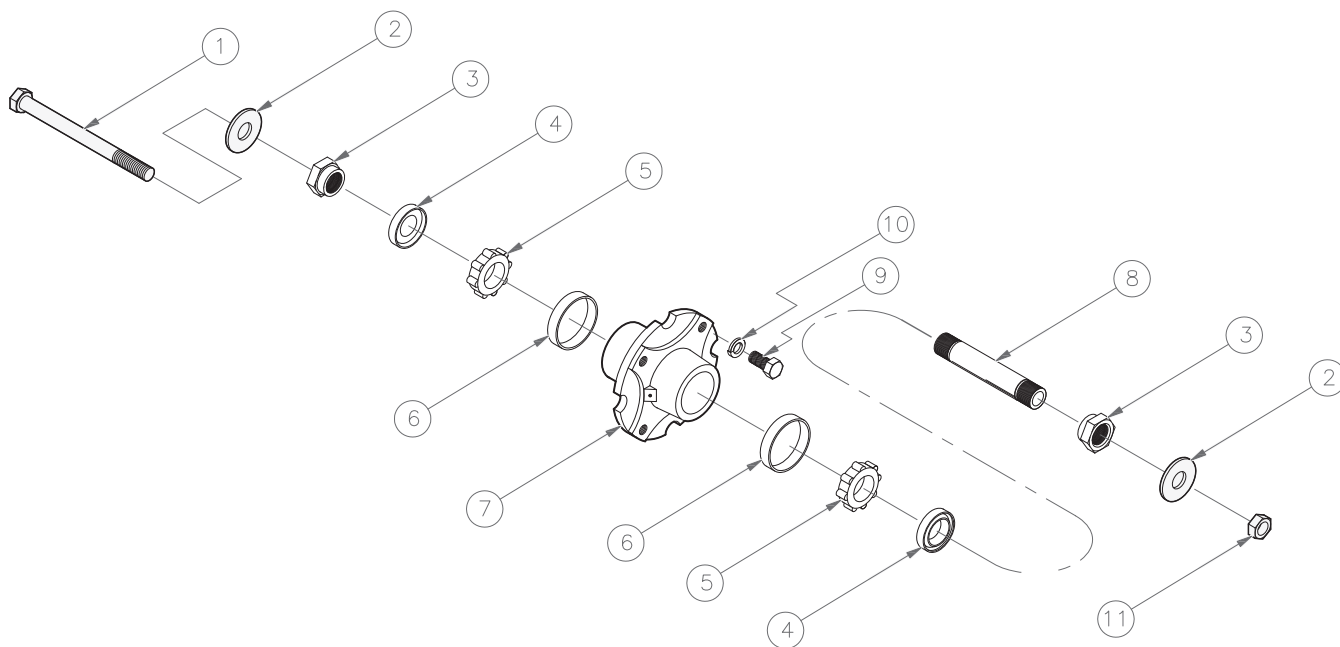

8' FT PREDATOR PARTS SECTION

401-0322 8' MOWER COUPLER

ITEM	PART NO.	QUANTITY	DESCRIPTION
1	501-0323	1	YOKE
2	343-1202	1	CROSS KIT
5	501-0327	1	SPIDER W. YOKE
6	501-0335	1	RUBBER DISC
7	501-0309	1	SPIDER
8	501-0324	6	SCREW AND NUT
9	501-0832	6	PLAIN WASHER
10	501-0330	6	BUSHING
11	501-0334	1	SCREW AND NUT

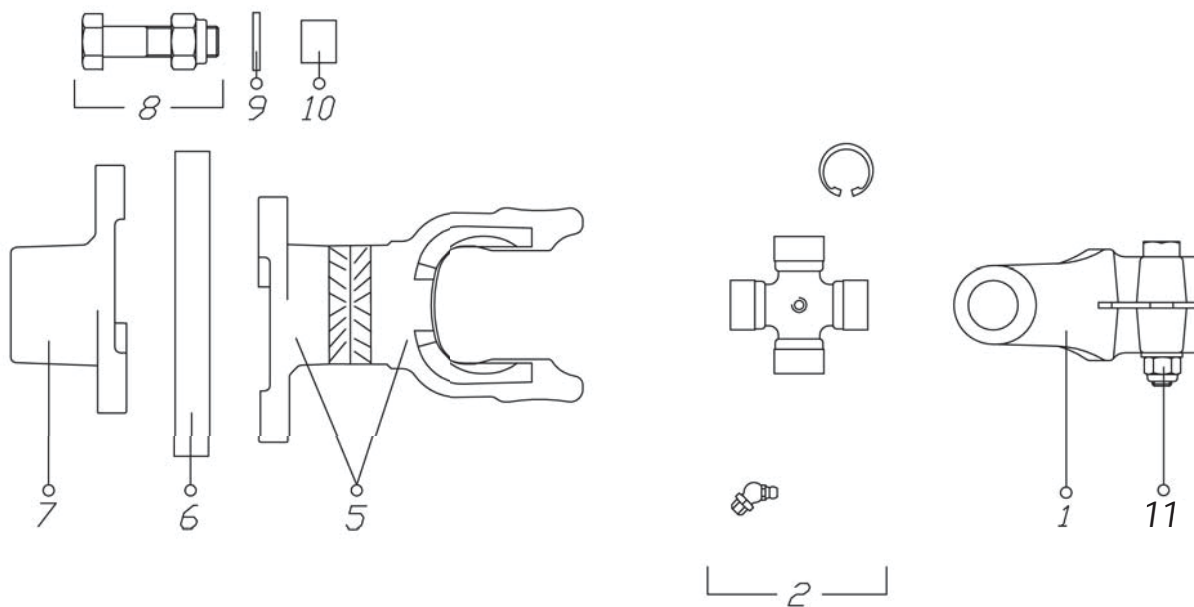

8' FT PREDATOR PARTS SECTION

This page intentionally left blank.

MODERN AG PRODUCTS, LTD. WARRANTY INFORMATION

A. Limited Warranties

Modern Ag warrants any new Modern Ag implement purchased from an authorized Modern Ag dealer to the purchaser for a period not to exceed one (1) year from original purchase date, to be free from defects in material and workmanship. Further, the Modern Ag galvanized rotary cutters will be covered by a limited warranty. This warranty provides a five (5) year limited gearbox warranty and a ten (10) year limited "deck rust thru" warranty. Under the five-year limited gearbox warranty, Modern Ag warrants the gearbox and labor for the first year from date of purchase. Following the first year, Modern Ag warrants the gearbox only. Warranty services must be performed by a dealer or service center authorized by Modern Ag using only new or remanufactured parts or components furnished by Modern Ag. Modern Ag reserves the right to inspect all parts which are claimed to have been defective in material and workmanship. Modern Ag makes no warranty as to the design, capability, capacity or suitability for the use of the implement.

B. Limited Warranty Service

To receive warranty service, the Purchaser must return the Registration and Warranty Card to Modern Ag within 30 days of original purchase. Purchaser must report claim, in writing, to the authorized Modern Ag dealer from whom the Purchaser purchased the implement originally or an approved Modern Ag dealer within 30 days after the Purchaser discovers the circumstance for the basis of the claim. The purchaser will be responsible for any service call and/or the return to and from the dealer's or service center's place of business.

C. Not Covered by Warranty

The limited warranty does not cover any goods or part(s) that have been subjected to improper or abnormal use such as negligence, abuse, alteration, modification, accident, lack of or improper maintenance, use of wrong oil or lubricants. This limited warranty does not apply to expendable items such as blades, shields, guards, pneumatic tires or any normal maintenance parts or service. Also not covered is wear items such as teeth, chains, sprockets, belts, springs, gearbox lubricant, hydraulic fluid or any other items that in the company's sole judgment is a wear item. The limited "deck rust thru" warranty does not cover surface rust caused by loss of galvanizing due to external forces such as scrapes, dents, extreme friction and/or wear, deformity due to accidents or abuse.

D. Disclaimer of Implied Warranties & Consequential Damages

Except as provided herein, no employee, agent, Dealer, or other person is authorized to give any warranties of any nature on behalf of Modern Ag. The purchaser's only remedies in connection with the breach or performance of any warranty on the Modern Ag implements are those set forth on this page. In no event will Modern Ag, the dealer or any company affiliated with Modern Ag be liable for incidental or consequential damages. Such incidental and consequential damages shall include but not be limited to transportation charges other than normal freight charges, cost of installation other than cost approved by Modern Ag, duty, taxes, charges for normal service or loss of crops or any other loss of income, rental of substitute equipment, expenses due to loss, damage, detention or delay in the delivery of equipment or parts resulting from acts beyond Modern Ag's control. Except as provided herein, no employee, agent, Dealer, or other person is authorized to give any warranties of any nature on behalf of Modern Ag.

**This form is required to be mailed with the completed Warranty Registration to
PO Box 790, Beaumont, TX 77704**

MODERN AG PRODUCTS, LTD. WARRANTY INFORMATION

DEALER: I hereby certify that:

1. The machine has been correctly assembled in accordance with manufacturer's instructions.
2. All bolts have been checked and tightened.
3. All other pre-delivery checks have been completed as per operator's manual.
4. Purchaser was given operators manual and instructed in safe and correct usage of machine and on limitation of warranty.
5. Machine was tested and operates correctly.

PURCHASER: I hereby certify that:

1. The machine is correctly assembled.
2. Receipt of the operator's manual which I have read and clearly understood.
3. I have a clear understanding of the warranty limitations.
4. I have a clear understanding on the correct and safe operation of the machine.
5. That the machine needs regular maintenance as per instructions in operator's manual.
6. I have a clear understanding on the capacity of this machine and am aware of its limitations.

MODEL: _____ SERIAL #: _____

DEALER: _____ DATE DELIVERED: _____

DEALER'S STAMP:

PURCHASERS' ADDRESS: _____

To register your implement and be eligible for warranty service, mail the completed Warranty Registration to

PO Box 790, Beaumont, TX 77704

If you have any questions, please contact wholegoods.warranty@modernusa.com